

AW 55-50SN / AF 23-33

Diagnosis and Valve Body Information

Presented by
Bob Warnke
ATRA Powertrain Expo 2008

sonnax[®]
TIME TESTED • INDUSTRY TRUSTED[®]

Adapting to the Aisin Warner 55 50SN valve body

Some things are less intimidating, if your not the first one to do it. That statement is relative to both the crossing of a frozen lake and a problematic 55 50SN. Because of a heavy snow cover, it cannot be assumed the ice is sufficient for support. What you cannot see may result in a sink or swim experience. On the 55 50SN valve body, a clean core is not indicative of the function.

This material is a route past the "thin ice" that other travelers have marked. At these flag's per say, the test or inspection, frequently points to the valve body, as it accounts for the majority of the transmission's issues. The 55 50/51 SN is installed into a multitude of vehicles and there will be variations to the unit and this data. A similar valve body will bolt to a GM, Volvo, Saturn, Nissan, Saab, Opel or Renault. Failure to test and recognize can create hours of additional effort.

Pressure and fill:

All the pressure plugs have a 12mm head. Do not mistake the 27mm band anchor (see Figures 1 and 2) for a fill plug or pressure tap. If that anchor is removed, the band will have to be recaptured. Positioning the band requires removal of the servo, at best and possibly the complete transmission.

The turbine sensor hole can be use to improve the fill speed. Low fluid or excessive overfill, can create erratic pressure and poor linear solenoid control, eventually forcing a TCM high pressure strategy.

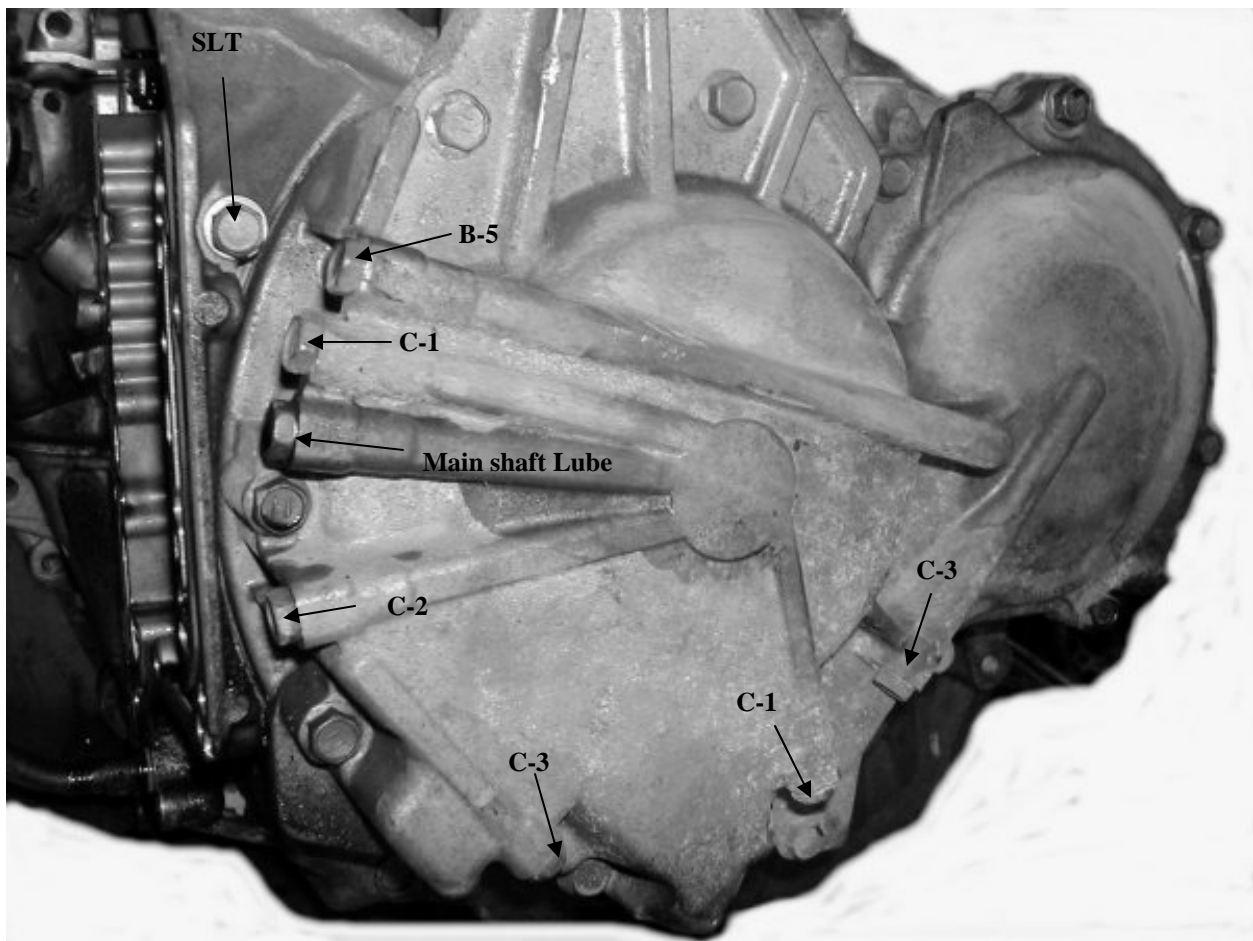

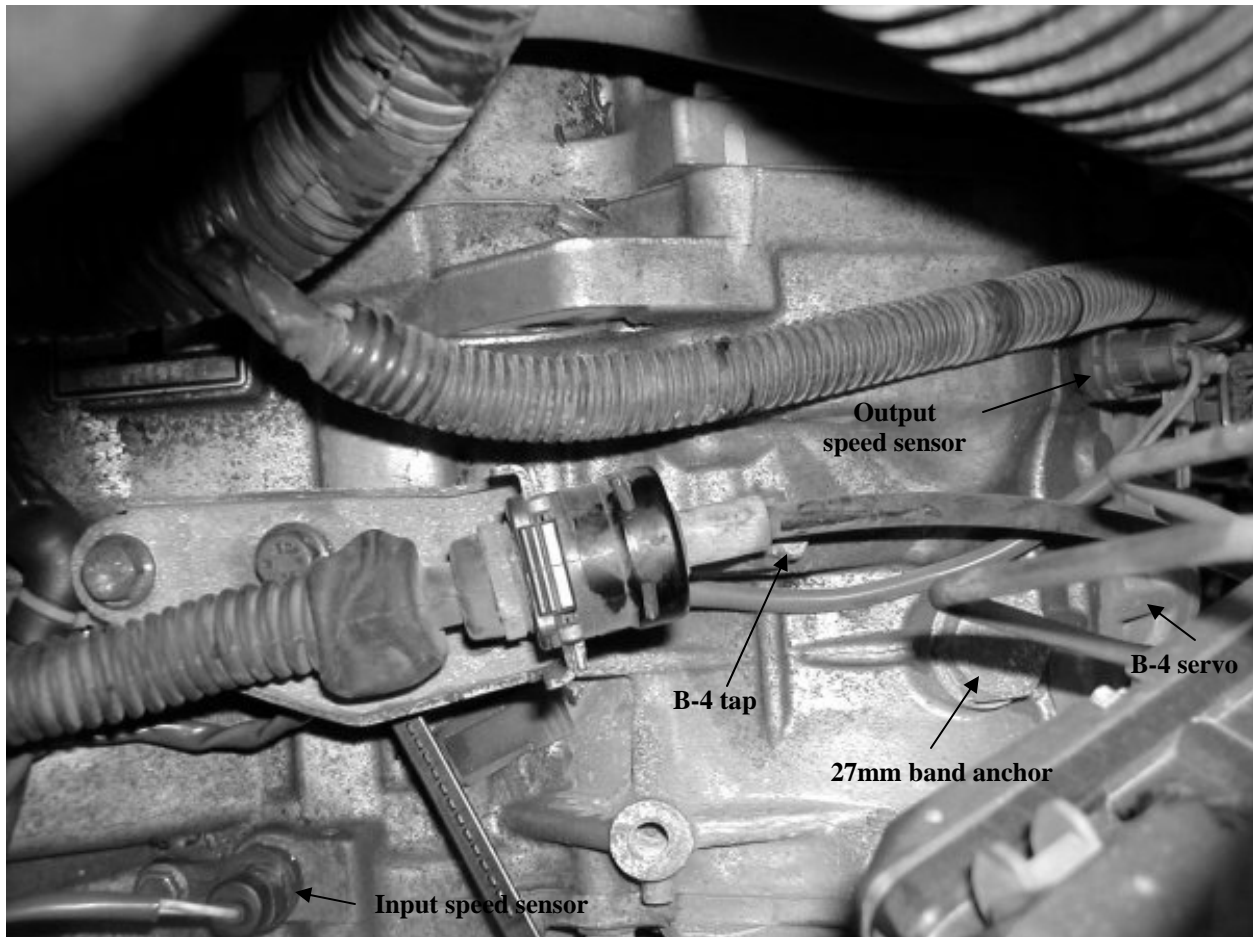

If the transmission is in the vehicle, “test the ice” per say, at the pressure taps relative to these complaints:

- TCC RPM fluctuation and overheated fluid

Check lube pressure. The lube pressure tap is between the secondary regulator valve and the main shaft bushings. Lube pressure will be affected by the fluid viscosity (flow rate) and the bushing to shaft clearance. Sufficient pressure at operating temperature indicates the filter, pump and both primary and secondary regulators are functioning. Normal lube pressure at the port indicated; -10 f. lube pressure can be as high as 30 psi. At 150 f, normal lube will be 5 psi. in Drive and 8 psi. in Reverse. This indicates the bushings are in place and can retain some of the source pressure. Lube pressure that starts low and stays at zero psi, would indicate your pump output is low, the regulator valve bore is worn or your bushings are bad.

If you are diagnosing a TCC complaint perform a cooler flow test. Normal flow in Drive with TCC released is 1.3 gpm and during TCC apply it drops to .7 gpm. The Saab, cooler element will require an adapter, but most units are easily accessible.

Lube pressure and flow on the 55 50SN, is low in comparison to other units. This converter requires multiple valves, along with the rear pump bushing, to control modulated TCC apply (see Figure 3). The converter clutch may remain fully applied at very low speed and high load, which taxes the fluid and lining, creating a break-away slip or RPM fluctuation.

- Delayed engagement and poor/flare shifts

Check SLT pressure and C-1 clutch. The C-1 clutch is engaged via pressure rise by SLT solenoid and through a series of modulated valves. The SLT pressure should start at 5 psi. in Drive and increase with throttle and load to 80 psi maximum. SLT will cutback and spike on various shifts, depending on the TCM program.

Typical C-1 pressure is -0- in Park. As Drive is selected, it quickly steps to 25 psi., then 50 psi, within half second and remains, until accelerated. C-1 psi. will then follow load, with a maximum near 200 psi. If C-1 pressure upon selecting Drive is immediately 160 psi. and obtains 200 psi. during a shift, the unit may be under a TCM code/ failsafe mode. Engagements at this time are abrupt. Some vehicles (Volvo specifically) may use a C-1 disengagement via brake signal creating a neutral at idle. Check for a TCM flash to eliminate this condition.

- 2-3 shift flare, neutral or harsh

Compare the B-4, servo apply pressure, to the C-1 clutch. The B-4 tap is at the top of the case, in line with the linkage bolts.

The B-4 circuit has extensive valve body control and includes a tube with o-ring ends that feed the servo. Comparing C-1 to B-4 is an indication of control by the SLS and SLT linear solenoids, a failsafe or leakage condition.

Proper B-4 pressure should follow C-1 and never be less than 10 psi. of C-1. (Refer to the C-1 pressure testing.) If C-1 psi. is fixed at 160 psi. upon engagement, the 1-2 and 3-4 shift, may be acceptable, but the 2-3 is generally too harsh. A TCM pressure management, code, aerated fluid or bad speed sensor, will eliminate the SLT pressure curve and force B-4 to an immediate 200 psi. which results in the harsh 2-3 shift. If the pressure curve of both C-1 and B-4 are parallel, C-1 initial engagement is near 50 psi. and the 2-3 harsh, the vehicle may require a flash update, but perform a key cycle and numerous drive cycles first. Some manufactures (Volvo) have servo's and a reflash to improve 2-3, 3-2 drive-ability.

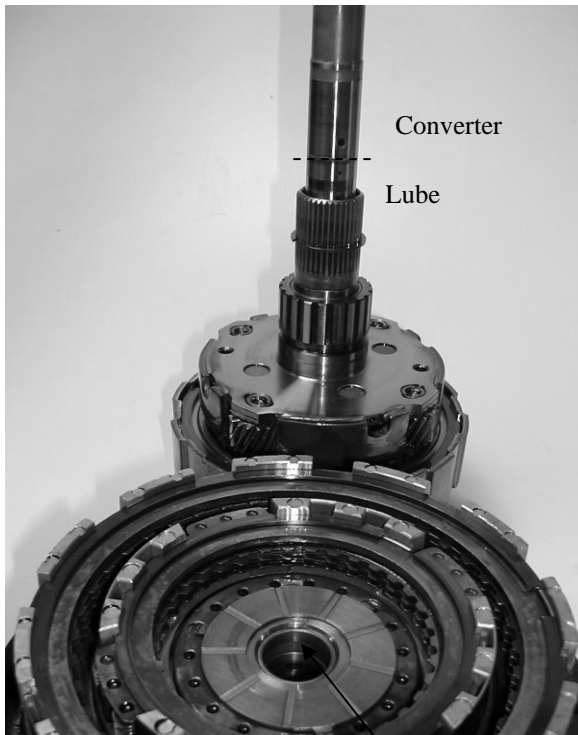

Critical pump stator bushing

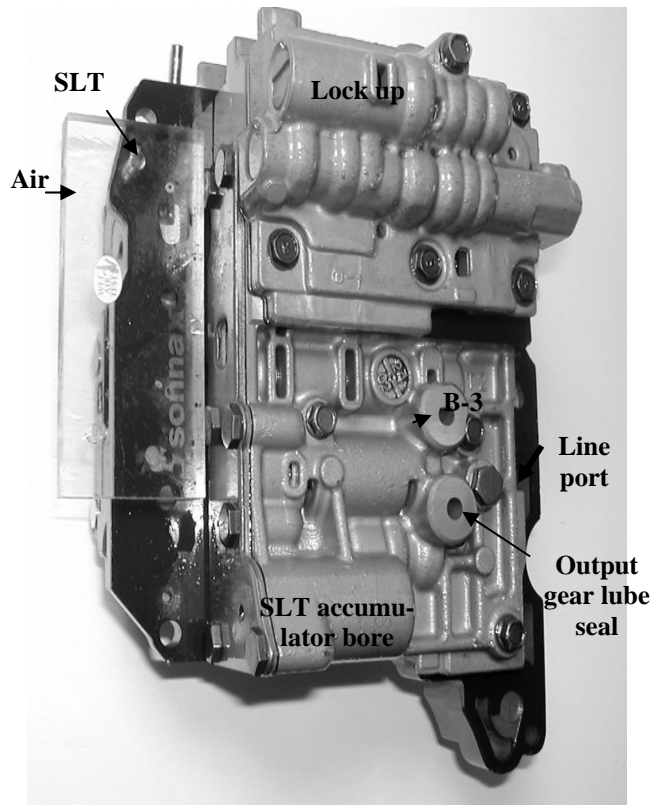

SLT air test:

Before removal of a valve body, from the transmission, you can perform a visual wet air test of the SLT circuit.

If you pressurize the SLT port with shop air (80-100 psi), air pressure will push fluid, which you see as a leak. Problematic leaks occur at the steel side cover, SLT accumulator, B-1 and C-1 control valves. A major leak or combinations, cause delayed engagement or flare up-shift and should be inspected after disassembled.

You can perform a similar air test (ill#4) with the valve body itself. When doing so, the pump line port and thermal element hole must be closed and the separator plate held as shown to eliminate cross leaks. This might sound confusing in print, but when you do it, the ports will be evident and easy to close with an opposite hand.

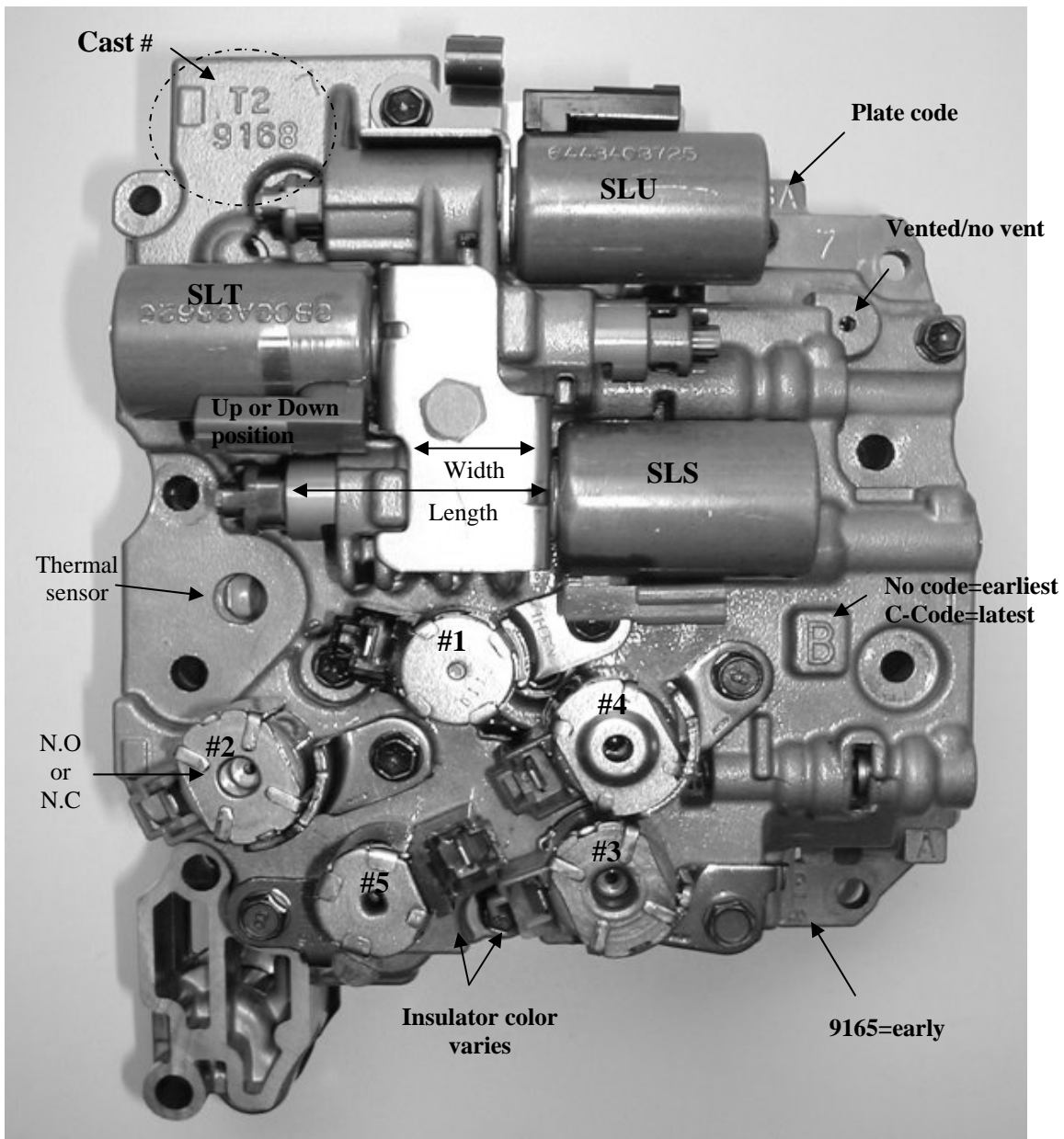

Valve body inspection:

There are many variations, which complicate coring and matching parts. Figure 5 identifies visual changes. Currently there are 6 different shift solenoids, 4 of which can be installed in incorrect locations or replaced by a normally open vs. normally closed solenoid. The shift solenoids should be checked for proper flow when open and their seal when closed. These are fed line pressure from an orifice in the plate and can be over pressurized.

Three linear solenoids are calibrated to the valve body. Exchanging SLT, SLS solenoids between cores, without adjusting to the valves, is generally not acceptable. Don't hesitate to open and inspect the valve body...as it's comparable to other Asian Warner designs and not difficult to reassemble. That inspection should include all the removable sleeves, both regulator valves and the solenoid modulator bore. The linear solenoids are fed by this modulator valve which limits the maximum pressure. When that bore is worn, the concern is similar to a bad GM actuator feed circuit.

Excess wear appears as a discoloration, or polished area, in the shape of a moon phase, generally at the ends of the bore or opposite side of fluid entry (see Figure 6).

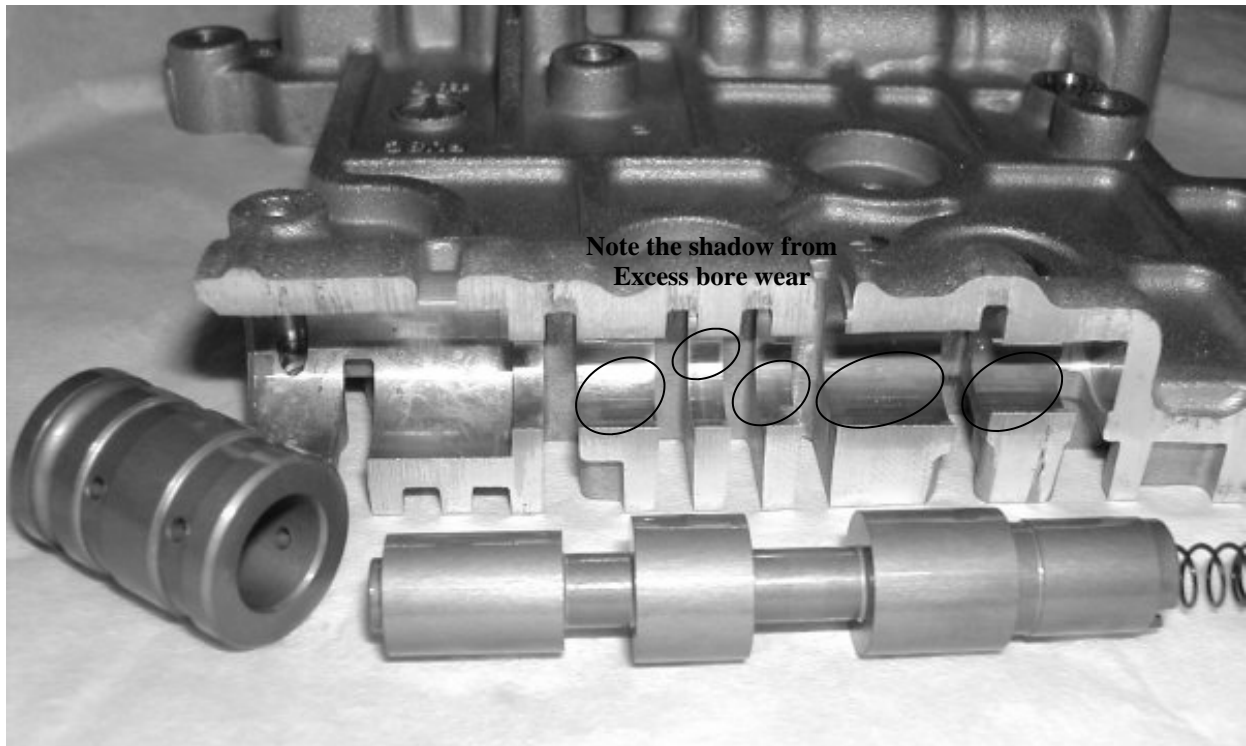

55 50 SN &/or AF-23/33

Solenoid	Connector	Wire(s) Color	Flow	Resistance	Function
SLU	Black	Green Brown	N.C.	5.0-5.6 ohms at 68°	TCC apply, reverse 1-2, 2-3 up/down shift
SLT	Blue	Green Gray	N.O.	5.0-5.6 ohms at 68°	Line rise, engagements, converter pressure
SLS	Green	Blue Red	N.O.	5.0-5.6 ohms at 68°	Clutch pressure, shift quality
S1	Black	White	N.O.	13.5-15.5 ohms at 68°	1st, 1-2 shift, reverse
S2	Black Gray	Black	N.O.-G.M. N.C.-Volvo	13.5-15.5 ohms at 68°	2nd, 3rd-4-5 shift
S3	Gray	Yellow	N.C.	13.5-15.5 ohms at 68°	Reverse, fwd-engage, 3- 4 shift
S4	Blue Green	Purple Red	N.O.	13.5-15.5 ohms at 68°	3,4,5, 2-3 shift
S5	Green Red Gray	Blue Black - '02 Volvo	N.C.-	13.5-15.5 ohms at 68°	Reverse engagement

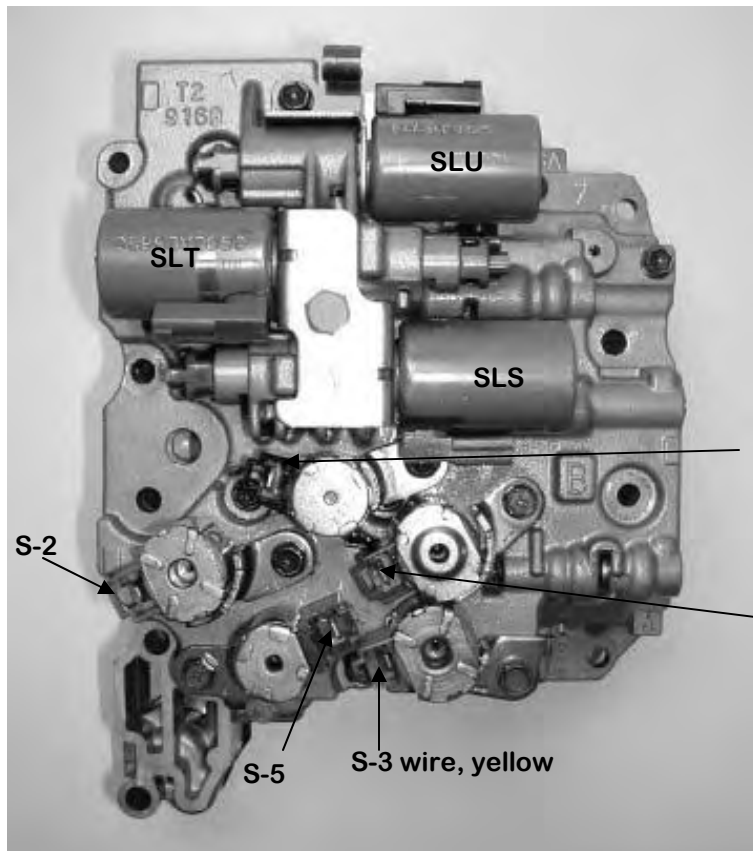

- Wiring Issues (see photo left)**
- Common to mix up connectors from harness
 - S1- White wire, right side loom.
 - S3- Yellow wire, left side loom.

Shift Solenoids					
	S-1	S-2	S-3	S-4	S-5
P	off	off	off	off	off
R	off	off	on	off	on
N	off	off	off	off	off
D-1	on	on	on	off	off
D-2	off	off	on	off	off
D-3	off	on	on	on	off
D-4	off	on	off	on	off
D-5	off	off	off	on	off

Solenoids S-1 and S-2 are on same TCM driver.

Solenoids S-4 and S-5 are on same TCM driver.

Solenoid S-3 is independent/separate.

SL Solenoids

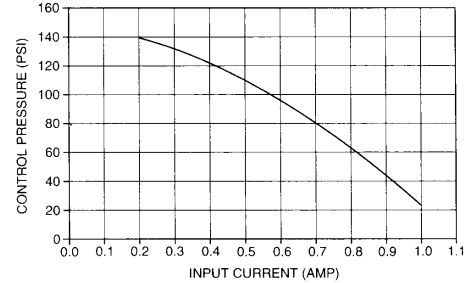
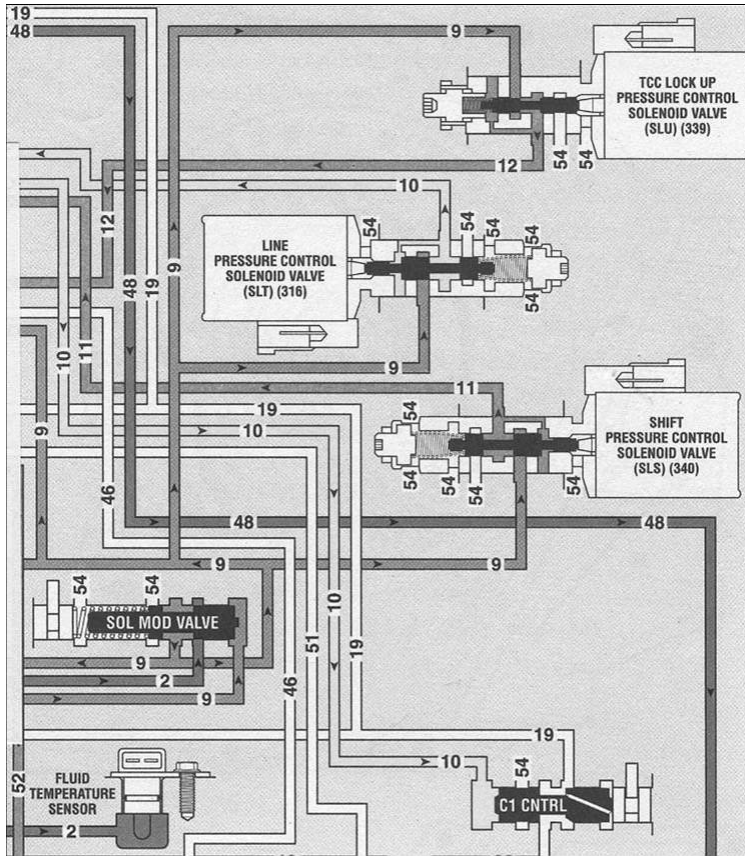

LINE PRESSURE CONTROL SOLENOID VALVE CURRENT FLOW

Note: This OE chart is referring to line pressure. Actual SL output is limited by solenoid modulator valve to 80 psi.

Measurement:
End of solenoid manifold to shoulder on adjuster

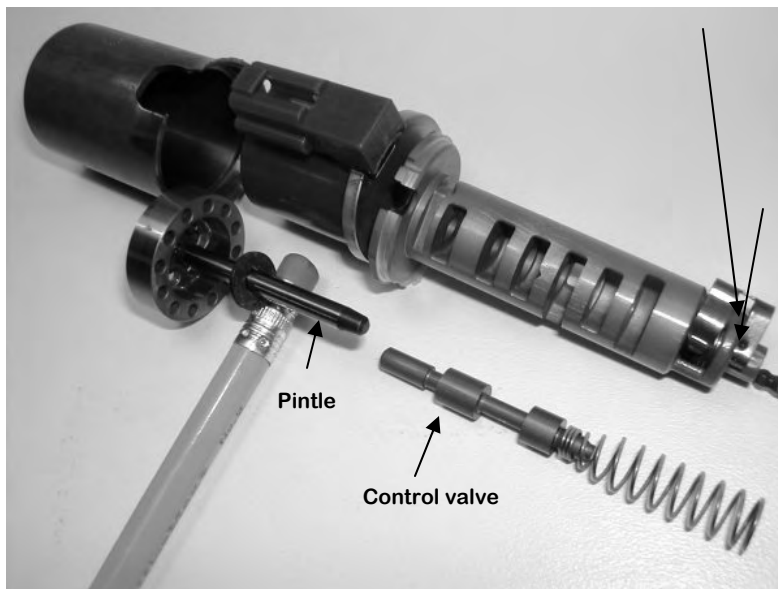

SLT-SLS
Preliminary adjustments: .010"-.050", record prior to removal.
Measurement taken with retainer removed. Shoulder of adjuster to end of manifold.
Turning screw inward, raises SLT & SLS pressure
6 clicks = 1/2 turn.
Turning screw inward, reduces SLU
6 clicks = 1/2 turn.

- Adjustment clicks are created by the increments on exterior of threaded allen, 3mm
- With control valve removed, shaking the coil should result in a free pintle movement.

All solenoids are 5.0-5.6 ohms and operate at 300Hz. Between 10 and 40% duty cycle.
Note: Bracket changes on Linear solenoids. Length of Linear SLT-SLS varies.

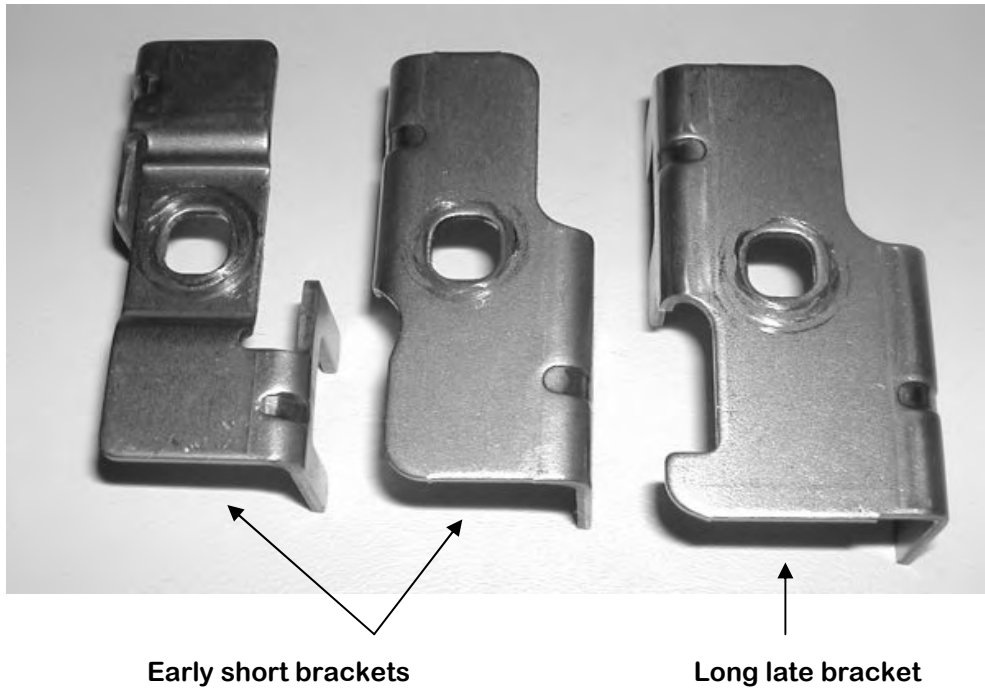
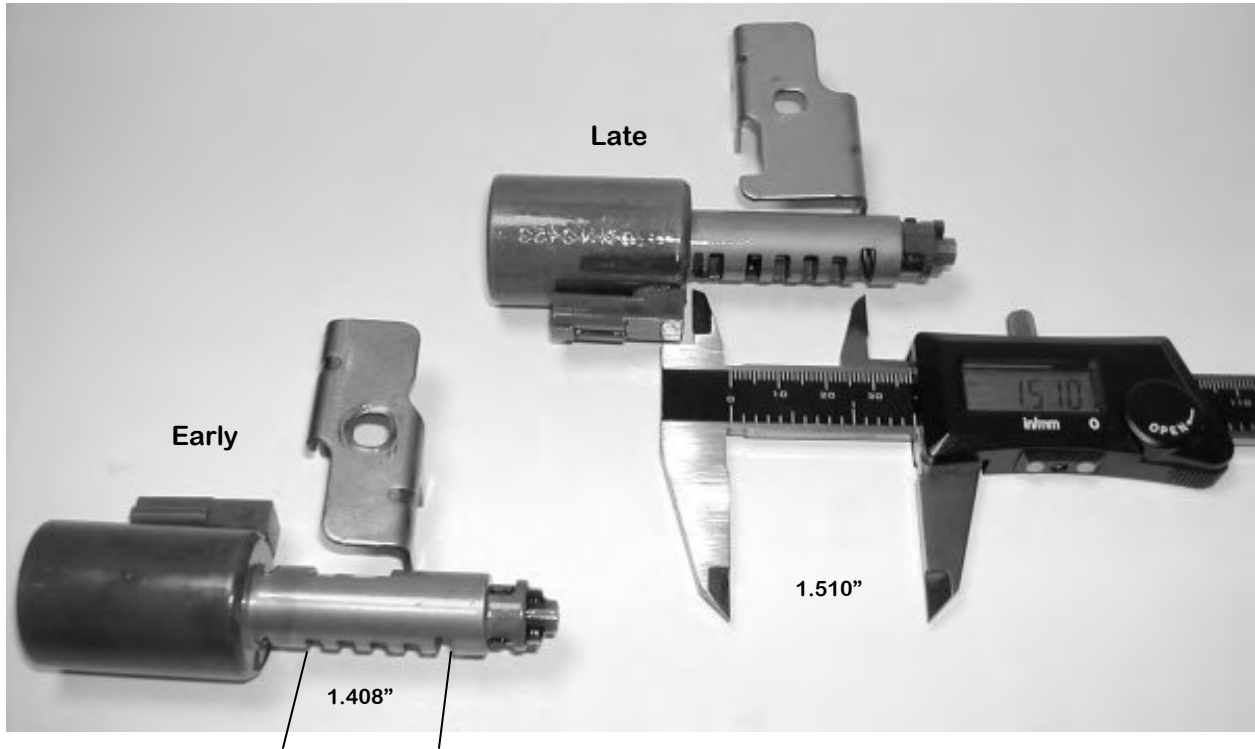

SLU-Remains same Early-Late

SLT-Early

- Slot for bracket results in solenoid connectors upward.
- Bracket is narrow type
- Distance bracket slot out ex. 1.408" (short manifold)

SLT-Late

- Slot for bracket results in connector down
- Wider bracket
- Long manifold 1.510"
- Connector down requires special harness, Volvo update.

SLS-Early

- Slot for bracket requires connector up.
- Narrow bracket
- Short manifold 1.408"

SLS-Late

- Slot for bracket requires connector up.
- Wide bracket
- Long manifold 1.510"

SLS-N.O.

- Controls clutch feed pressure at shift pressure control valve.

SLU- N.C.

- Controls TCC apply
- B-4 servo apply
- B-2 neutral control

Rebuild Comments:

G.M. & Saab use different TCM strategy compared to Volvo & Renault.

Limp mode is not always 5th gear.

Input & output speed sensors are Hall affect.

Be sure to clean them and keep away from stray frequency.

Harsh shifts, high line pressure & TCC concerns can be caused by input contamination, also Gear ratios, TCC cycling, 3-5 shift, phantom codes.

Add ground straps & distance the sensors from Linear solenoid wiring.

Valve body exchange:

G.M. Equinox valve body has been installed successfully onto Volvo. In order to do so, a wiring harness must match SLT Linear connector either positioned up or down.

- #2 solenoid is N.O. on G.M. must use Volvo N.C. on #2
- Always resurface castings on all valve body areas.
- Seal end plugs for C-1 control, B-4 release, B-1 control

SL Solenoid Access

The side cover can be drilled and plugged to adjust the linear solenoids. Cover must be removed for this procedure!

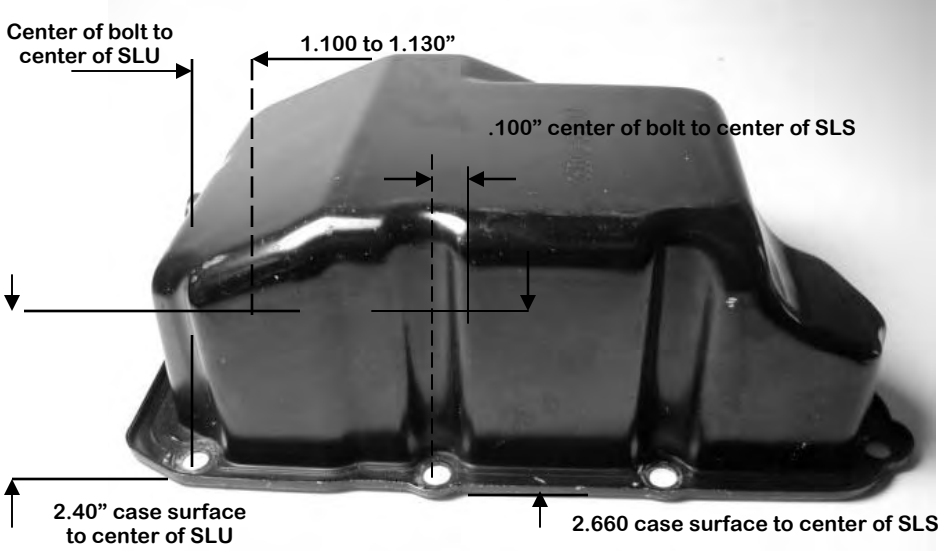

Hole size depends on what plug you use. 1/4" blind head rivets are an option. Seal with silicone upon install.

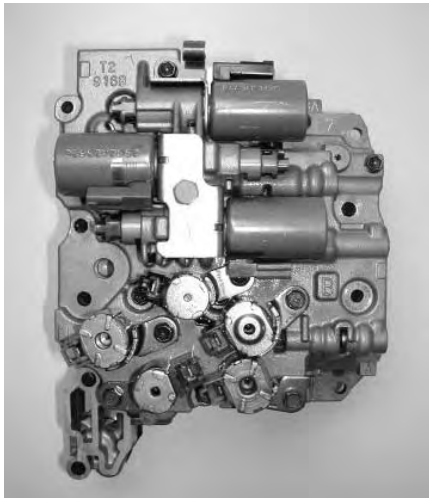
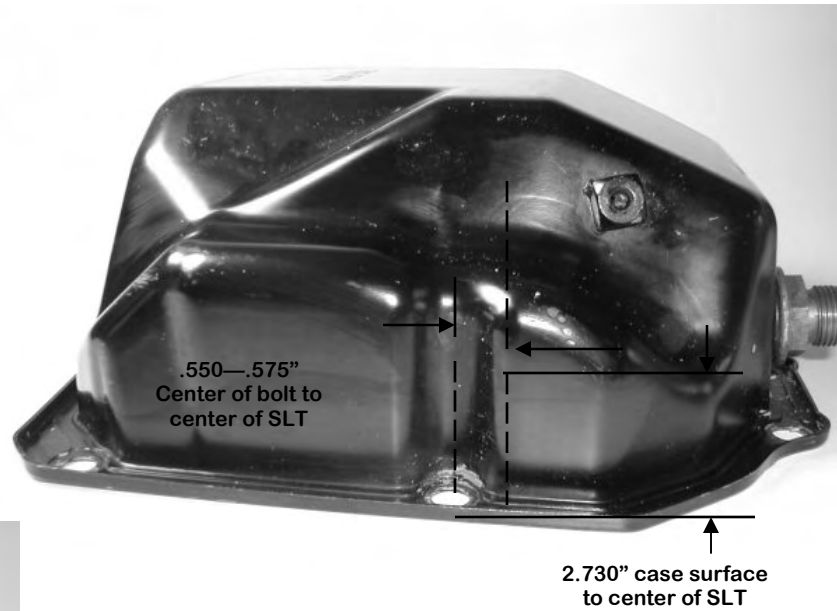

Linear Lock-up Solenoid (SLU)

This solenoid affects:

- 1-2 up-shift. ie; too firm or bumpy
 - 2-1 downshift. ie; harsh, bump
 - Light throttle TCC modulation. ie; cycling rpm or cooler flow
 - Full TCC lockup. ie; late, bump on coast down release
 - TCC release on coast; too early, loss of engine braking
- Refer to the pressure chart for examples of operation.

SLU service and adjustment at the bench:

- Pre-measure the adjuster, (figure) remove the threaded adjuster, then the valve from the solenoid.
- Verify the pintle (shaft passing through coil), is free floating by performing a shake test.
- Re-assemble and turn the adjuster to the original position.

Drive-ability and VBT test stand verification:

- The SLU is pulsed during 1-2, 2-1, 2-3, 3-2 shift, also during engagement into Drive or Reverse and TCC apply. Monitoring cooler flow with a Sonnaflow will indicate if the SLU is adjusted properly. A quick flow reduction of 50% and then a return, indicates the SLU is reacting to TCC valves. For example, 1.0 gpm. in Park, then upon Drive engagement, a sharp drop to .06, and a quick return, identifies the correct action.
- If you have harsh up/down shifts and you do not see a cooler flow toggle, the SLU is not adjusted or working properly.
- The correct adjustment on SLU will increase cooler flow. Improper adjustment will reduce cooler flow, substantially.

SLU adjustment in the vehicle:

- The solenoid can be adjusted if a pass-through hole has been located in the cover during bench rebuild. (figure). The SLU access will be at the top, left corner. A 3 mm Allen wrench, will pass approximately 1.60" or 40.9 mm. through the cover, when it's inserted into the adjuster. You should be able to feel the Allen engagement. As you turn the Allen wrench you will feel the retainer click over the index. Always count your rotations, in clockwise (CW) or counterclockwise (CCW), so you know where you start /stop.
CW/ In : Reduces SLU output.
Resulting in: hard 1-2, 2-1 shifts and firmer/late TCC
CCW/ Out: Increases SLU output. Resulting in softer shifts and earlier TCC

Road test:

- If your TCC control, 1-2 and 2-1 are good, cooler flow drops properly as noted above, leave the adjustment as is. If not, adjust accordingly.
- Slight bump on 2-1 down-shift... and/or TCC rpm fluctuates at 30-40 MPH during modulated apply....and/or excess TCC slip at full lockup...and/or Sonnaflow sensor indicates TCC control valve is continually toggling on-off.
If so... turn adjuster screw in/clockwise 1.0 turn.
- Harsh 2-1 downshift....and/or heavy TCC RPM fluctuation at 30-40 mph...and/or late and firm full TCC apply. If so...turn adjuster in/clockwise 1.5 to 2.0 turns.
- TCC will apply not modulate slip RPM at 30-40 mph. Beyond 40 mph, TCC apply is short and harsh.... and/or a harsh TCC release on coast and/or 1-2 shift is too harsh. The adjuster is too far inward, back it out/ counter clockwise as required 1.5 to 2.5 turns.
- Low cooler flow when in lockup. No TCC flow drop upon engagement or shifting. Adjuster may be too far out/CCW.

Note:

The spring between the adjuster and the valve tends to have some memory or coil wrap up. If you over-compensate in one direction, it may require more of an opposite direction to restore!

During road test, you will need a temporary plug in the access holes.

If you can feel the adjuster turn out against the retainer, STOP... or you can force the retainer off. If you have adjusted to this point, you are beyond resolving a problem with a solenoid adjustment. Generally 1-2 turns in/ out is all that is needed.

Line Pressure Solenoid (SLT)

This solenoid affects:

- Reverse engagement. ie; too firm, or delay
- Forward engagement. ie; delay forward
- Upshift/downshift quality. ie: harsh upshifts, coast down clunk
- 2-3 upshift. ie: long flare, or tail bump
- SLT pressure tap. Pressure too low, and slow response.

Refer to the pressure chart for examples

Solenoid service and adjustment at the bench:

The service procedure is the same as the SLU and SLS. Measure before and return the adjustment after cleaning.

Drive-ability and VBT test stand verification:

The SLT is the line rise control solenoid. It sets the position of the C-1 clutch control for forward engagement. It positions the B1 valve for second clutch feed on 1-2, 2-1 shifts. It boosts secondary regulator valve, converter and lube pressure and controls 2-3 shift at the B-4 control valve. It is a very critical adjustment!

Insure the end plugs at these valves are sealed and secondary regulator bore is not worn or this pressure is either lower, or too high. High SLT and harsh Reverse can be caused by bore wear at the secondary regulator bore, near the spring spool.

This solenoid operates at 300 Hz, and has control between 15 to 45 % duty.
Refer to charts and review SLU.

SLT adjustments in the vehicle:

This access hole is on the right side of the cover, easiest to adjust of all three. You must monitor this pressure with a 0-100 psi gauge, to set accurately. OE correct SLT, is approximately 5-6 psi. in Drive range. Maximum obtained SLT is 78 psi.
Turning the SLT screw inward/clockwise, increases the SLT pressure.

High SLT pressure causes:

(CCW / out, reduces SLT)

Example; 20 psi. of SLT in Drive

Results in long 2-3 shift, or an overlap / bind up on 2-3. Also a 3-2 coast down bump. Forward engagements become harsh. TCC apply ramp becomes short and there can be a loss of TCC modulation slip at lower speed. Lube pressure and cooler flow become less at excessive SLT pressure.

Low SLT pressure causes:

(CW / in, increases SLT)

Example: -0- SLT in drive.

Causes a Neutral to Drive delay, often with a bang engagement. Long shifts and lower than desired cooler flow.

Note: Increasing SLT , generally will not eliminate a 2-3 flare. Check servo design and travel. Then test B4 pressure tap, It should be parallel to C-1.

Shift Pressure Control Solenoid (SLS)

This solenoid affects:

- Reverse engagement.
- Upshift and downshifts.
- Does not affect forward engagement.

This solenoid pressure only reacts on the shift pressure control plunger to adjust clutch pressure. It is pulsed to control the feed rate of the clutch dependant on engine load.

Refer to the application chart.

The service procedure is the same as the SLU, and SLT above.

Drive-ability and VBT test stand verification:

The valve body has an SLS access on the back-side, with a 10mm hex nut. It is not accessible in the vehicle. On the VBT the solenoid is operated at 300 Hz. To duplicate the correct on-car operation, this solenoid would have the duty % lowered during each up/ down shift.

Pressure ranges from -0- to 78 psi.

Insure the end plate on the rear control body is flat and the bore of the outer sleeve is not worn. Generally these do not wear in excess.

SLS adjustments in the vehicle:

The access hole will be located on the left side of the cover, lower than the SLU and in the bolt radius of the cover. Turning the SLS screw inward/clockwise, increases the SLS pressure.

High SLS pressure causes: (CCW/ out, reduces SLS pressure)

Harsh reverse.

1-2 shift harsh.

2-3 harsh with an end bump.

Loss of TCC apply.

Elevated C-1 clutch pressure.

3-2 maneuver flare/ bang . Note: Some of the 3-2 bang complaints are caused by a non-compatible valve body. Some of these 3-2 flare, can be reduced with SLS adjustments.

Low SLS pressure causes: (CW/ in, increases SLS)

Soft upshifts.

Low speed 2-3 flare

Slight RPM flare on 3-4, 4-5 shifts.

Note: SLS does not affect forward engagements.

SLU SOLENOID

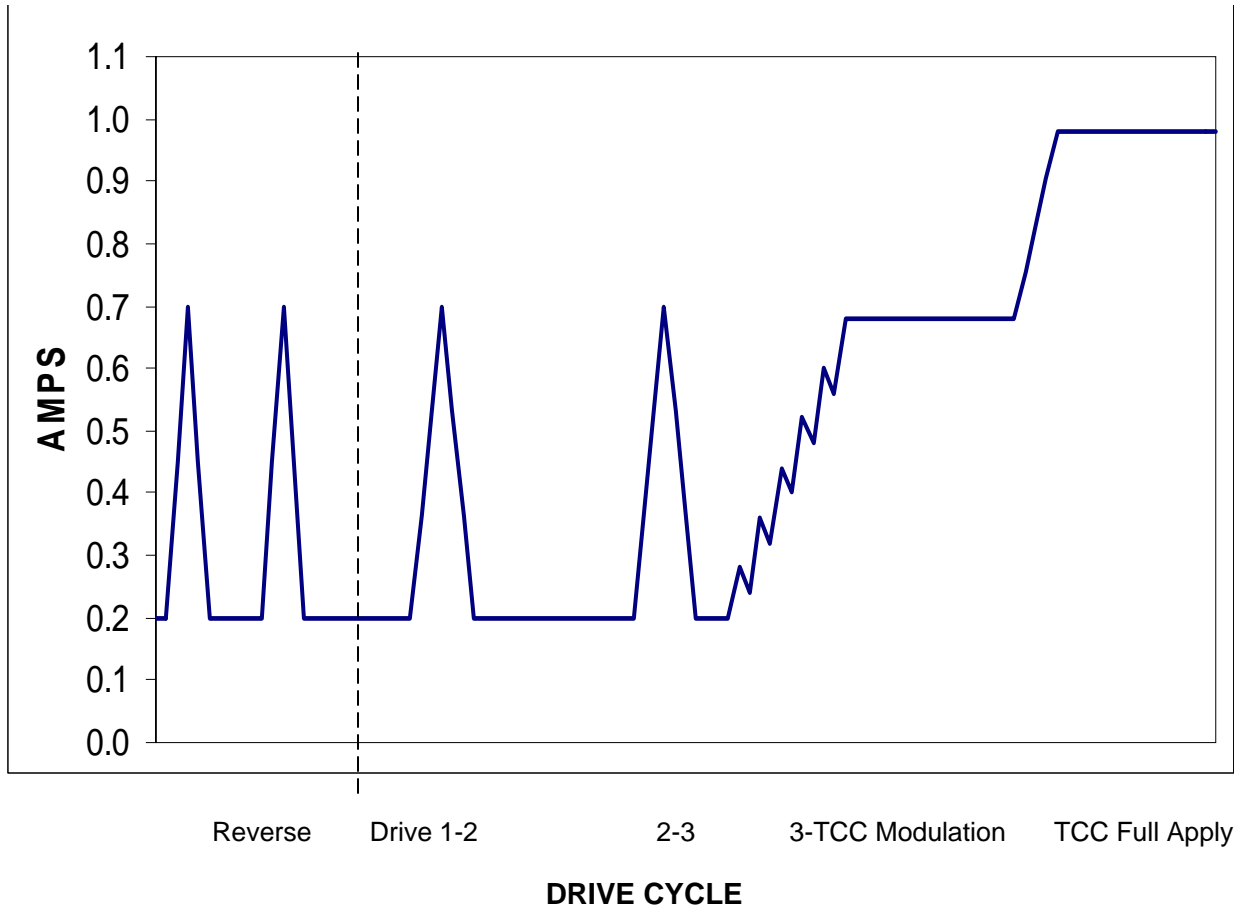

High current causes high pressure
 Solenoid is Normally closed (N.C.)
 300 Hz operating frequency 15%-48% duty 1 AMP, TCC is off.
 SLU controls 2nd clutch (B-2) and low reverse (B-3). Manual low for engine, braking
 SLU- Has been know to create 1-2 slip, 2-1 harsh downshift if not adjusted or defective. It also can over heat fluid and affect TCC apply.
 SLU generally controls TCC right after 2-3, and will maintain TCC apply coasting or cruise at 25 mph.

Chart Example: '03 Volvo V70 XC

SLT SOLENOID

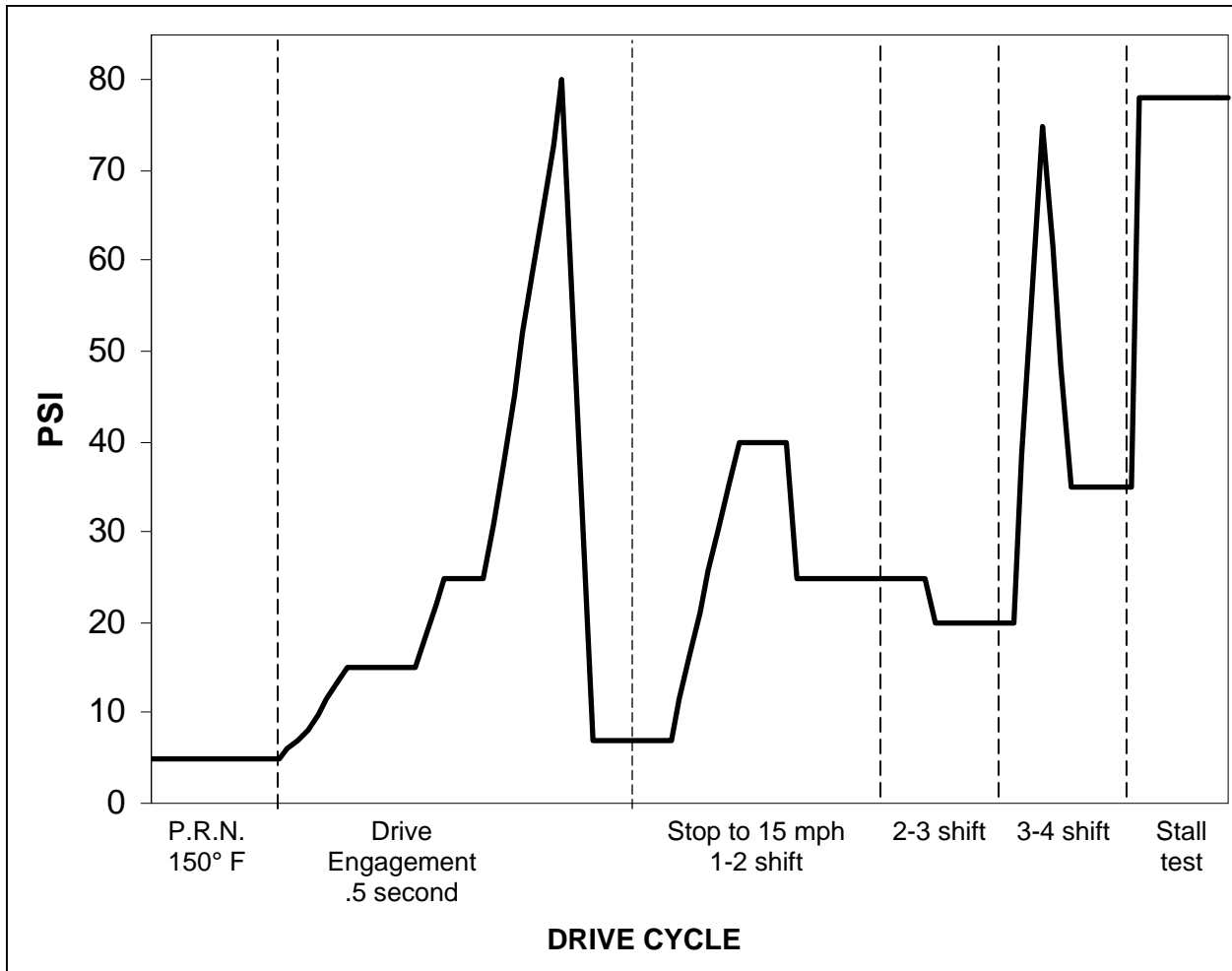

300 Hz operating frequency 15%-48% duty
 SLT is normally open solenoid (N.O.)
 Low current causes higher pressure (inverse proportional)

Chart Example: '03 Volvo XC 70 Vehicle data

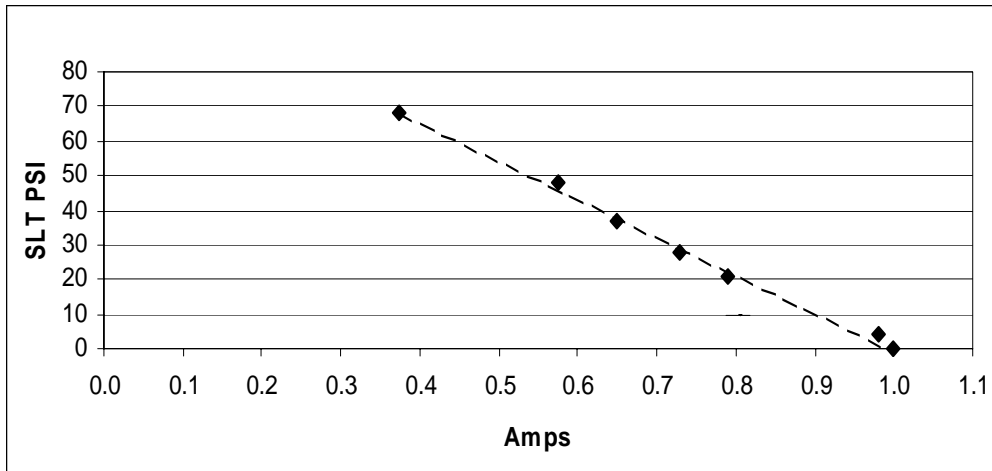

SLS SOLENOID

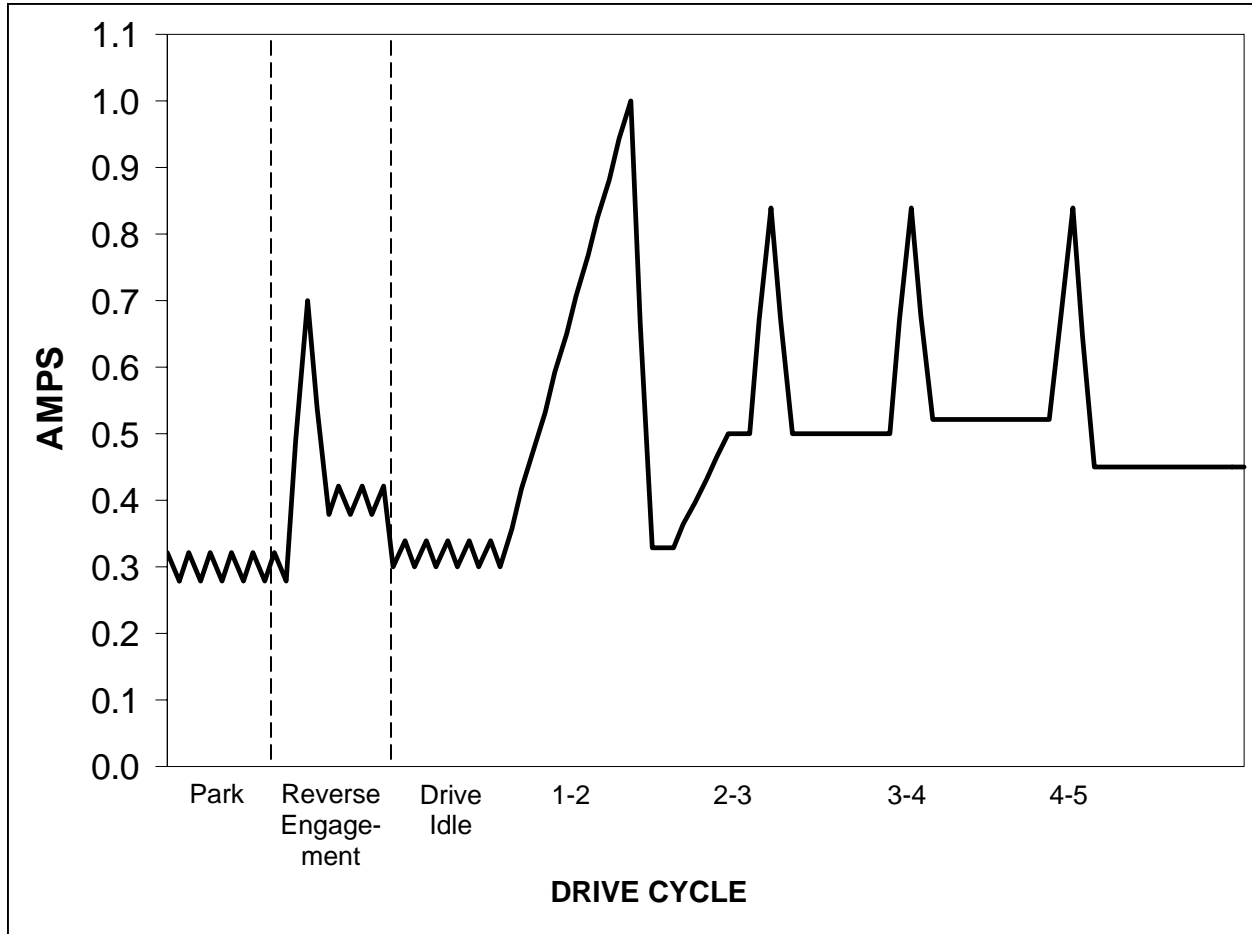

300 Hz operating frequency @ 15-40% duty

SLS is normally open solenoid (N.O.)

Low current causes higher pressure (inverse proportional)

This solenoid is spiked to increase clutch feed, then modulated between shifts.

Coast down shifts are modulated also with a pressure rise after each shift.

SLS controls: 2nd, 3rd, 4th, B-1 brake, 5th, Reverse, C-2 clutch

Chart Example: '03 Volvo V70 XC

C-1 CLUTCH PRESSURE

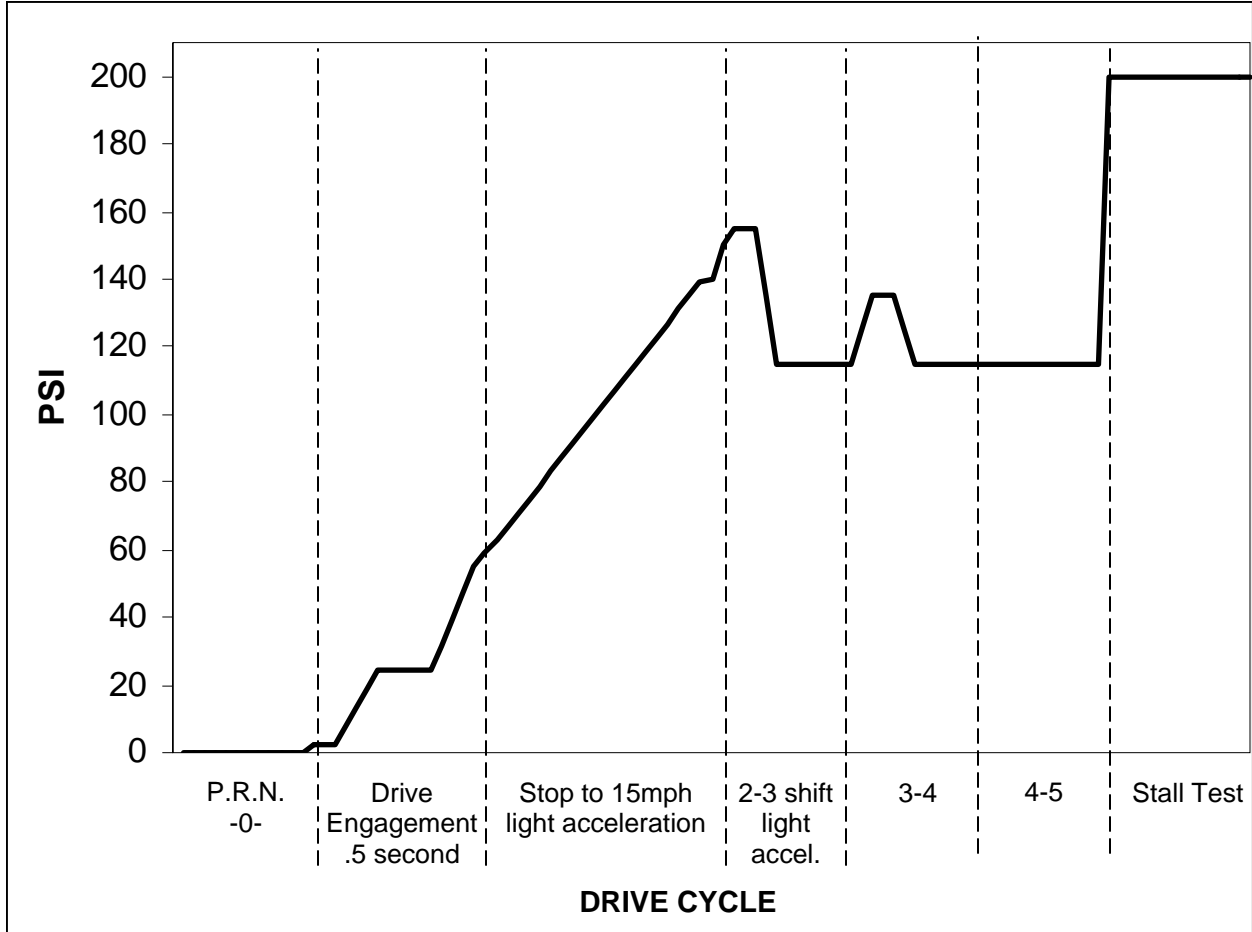

Note: If C-1 pressure upon initial engagement is 160 instead of the 50-60 psi, the TCM has commanded a pressure rise. Verify with SLT amperage, then check for codes and electrical issues.

APPLICATION: 55 50 SN &/or AF23/33 Volvo '02 (130,000 m)

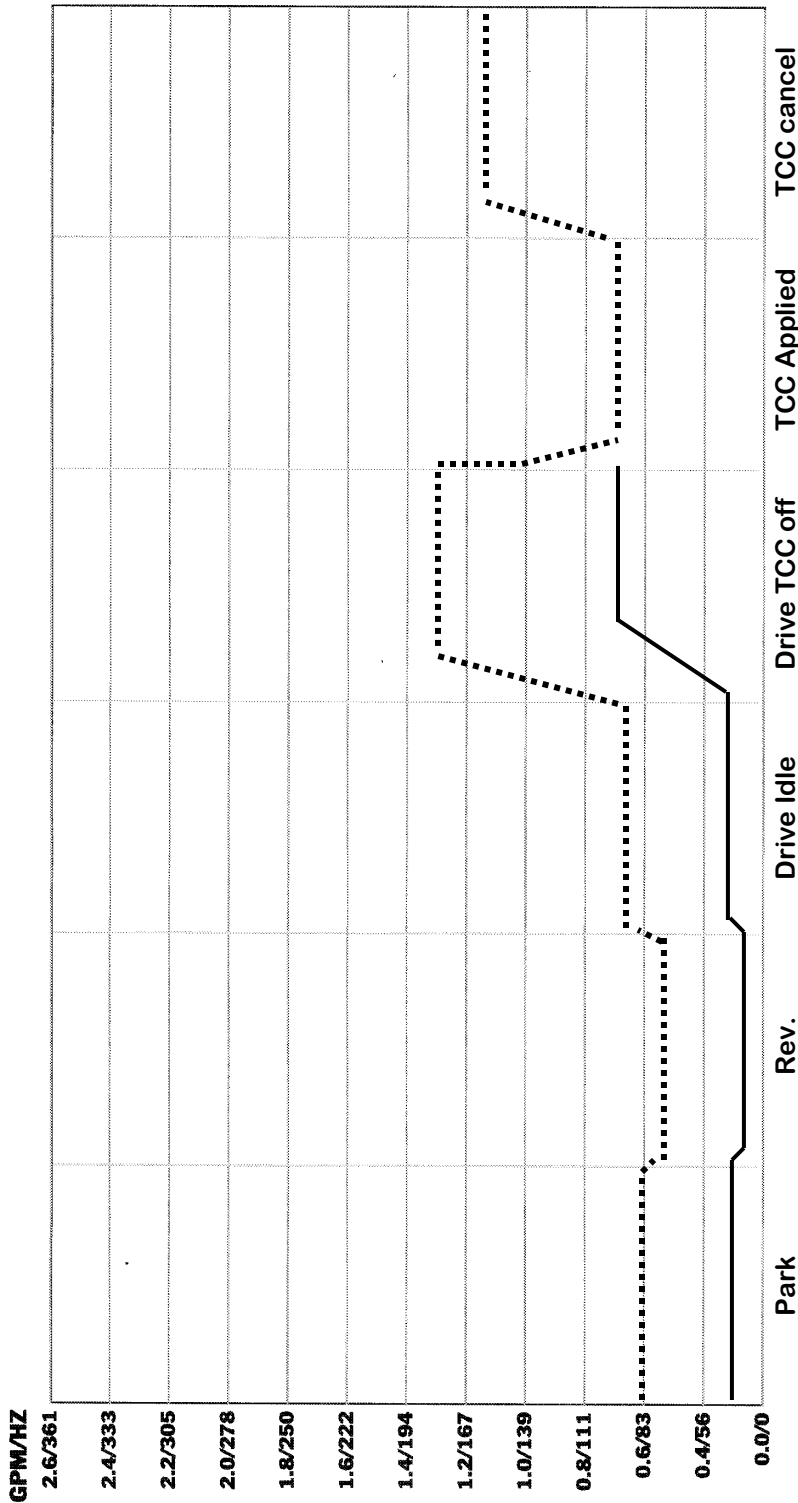

Event: Normal conditions

Condition: Cooler flow — 8°F Cooler flow 150°F

Lube pressure: 8° F 12 psi P 150° F 9.0 psi P
 OEM: 8° F 34 psi Revs. 150° F 9.2 psi Revs.
 Cooler lines: 8° F 24 psi Drive 150° F 6.0 psi Drive

FRONT CONTROL BODY

Fig. 1

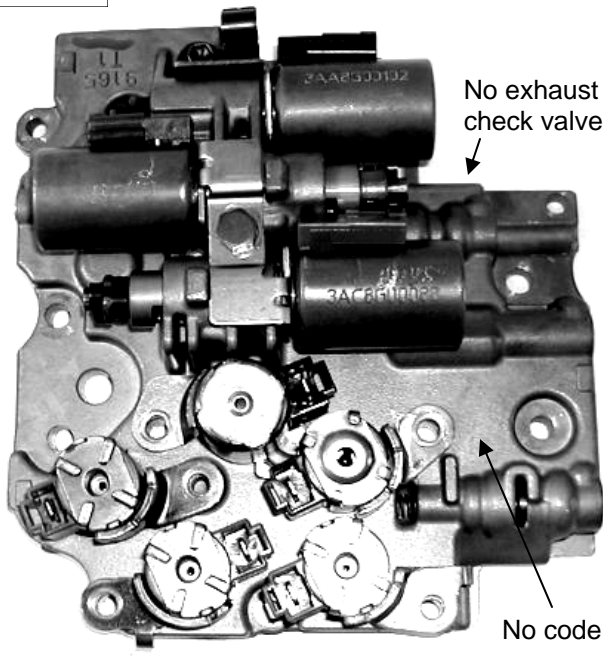

This casting does not match the GM AF-23 oil circuits in Blue Technicians guide.

Fig. 2

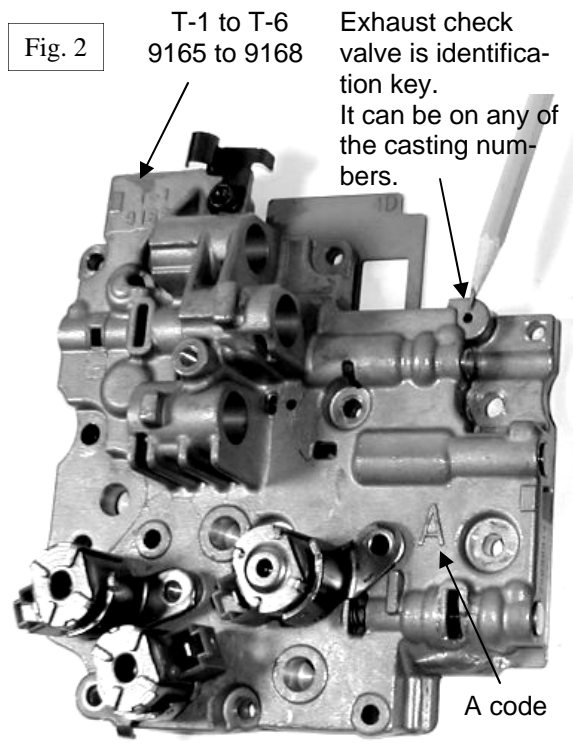

Code: No = Early
C is late

Typical of the updated Volvo, C valve body

Fig. 1

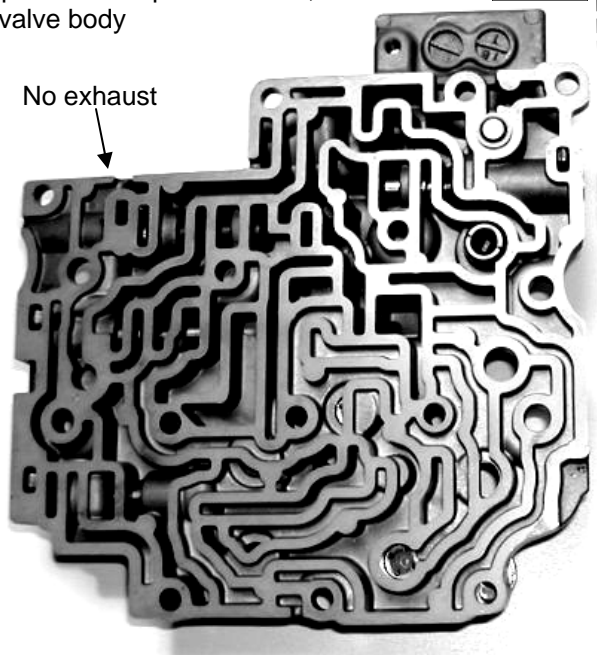

Exhaust Casting matches GM AF-23 Technicians guide oil circuits.

Fig. 2



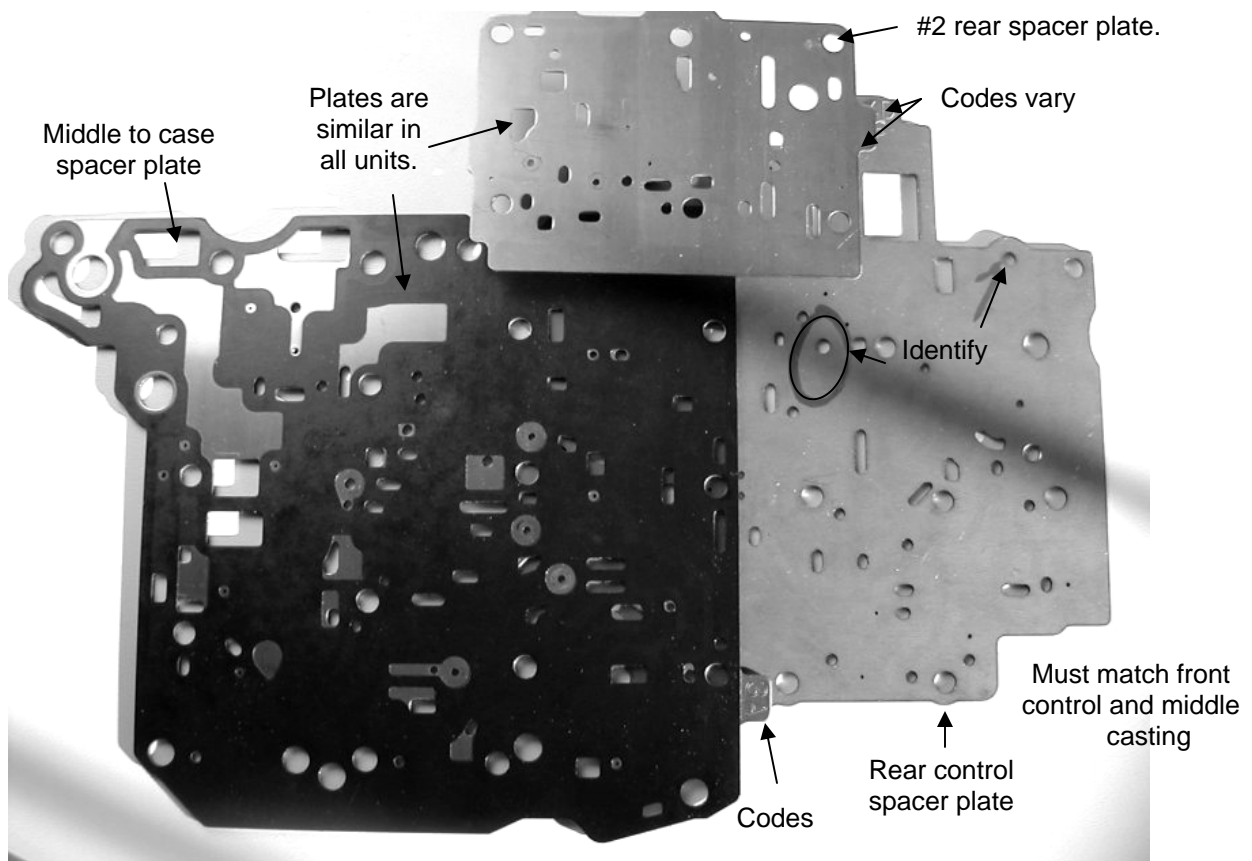
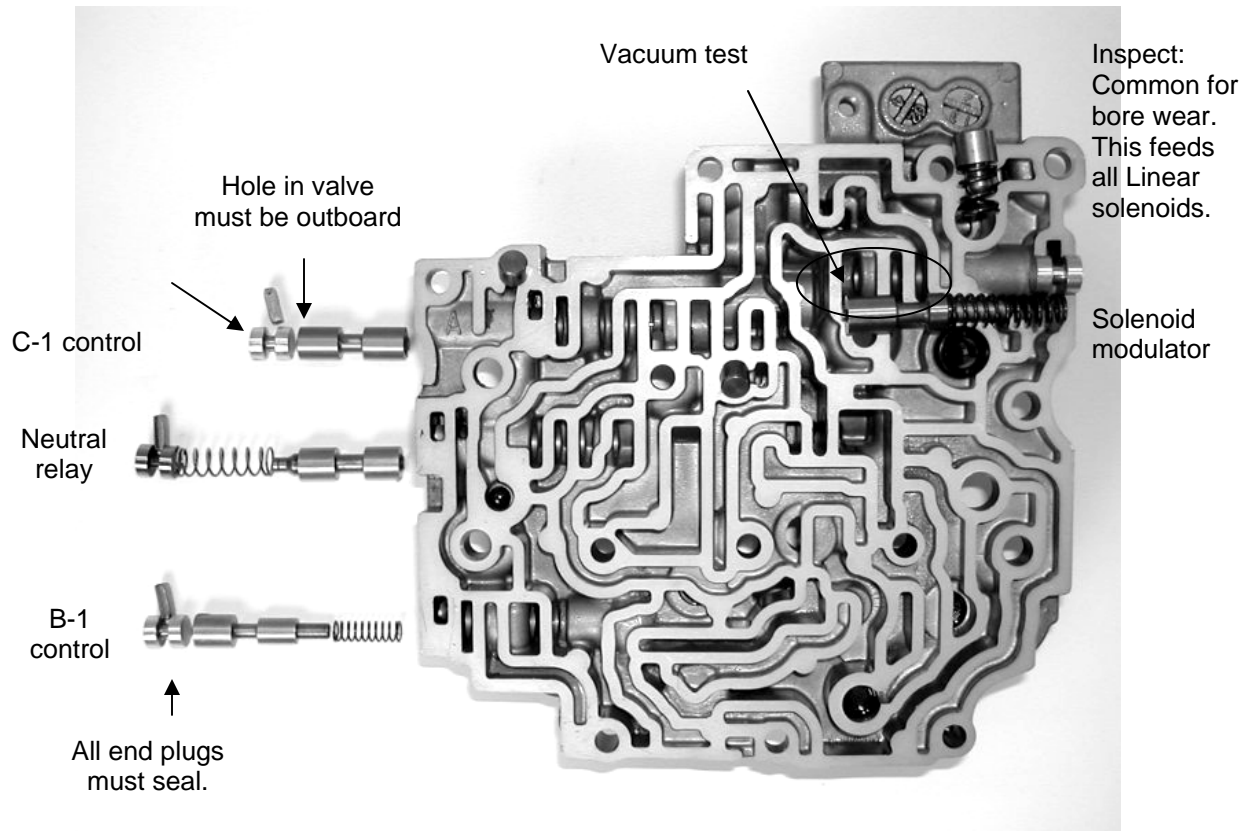

MID-CASTING:
Cover Side

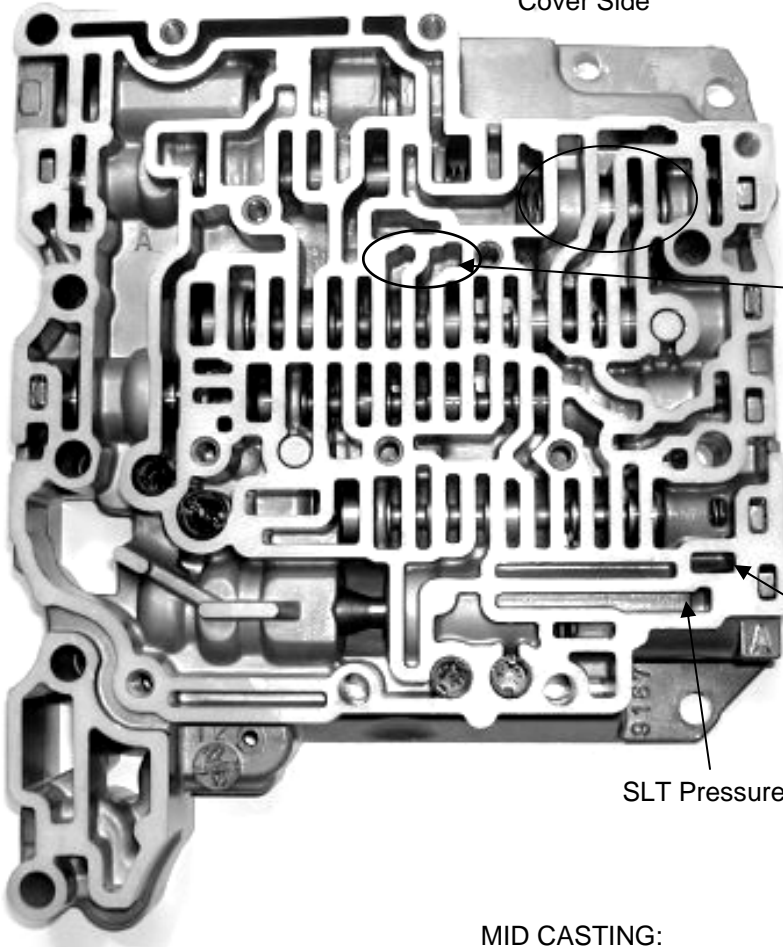

- Inspect for visible wear & scoring.
- Vacuum Test, minimum of 18" vacuum.

This casting (two flags):
Must go with exhaust type
plate and front control.

*One flag on right only:
Assembles with a non-exhaust
plate & front control.

Boost sleeve vacuum test

SLT Pressure

MID CASTING:
Case & Rear Body Side

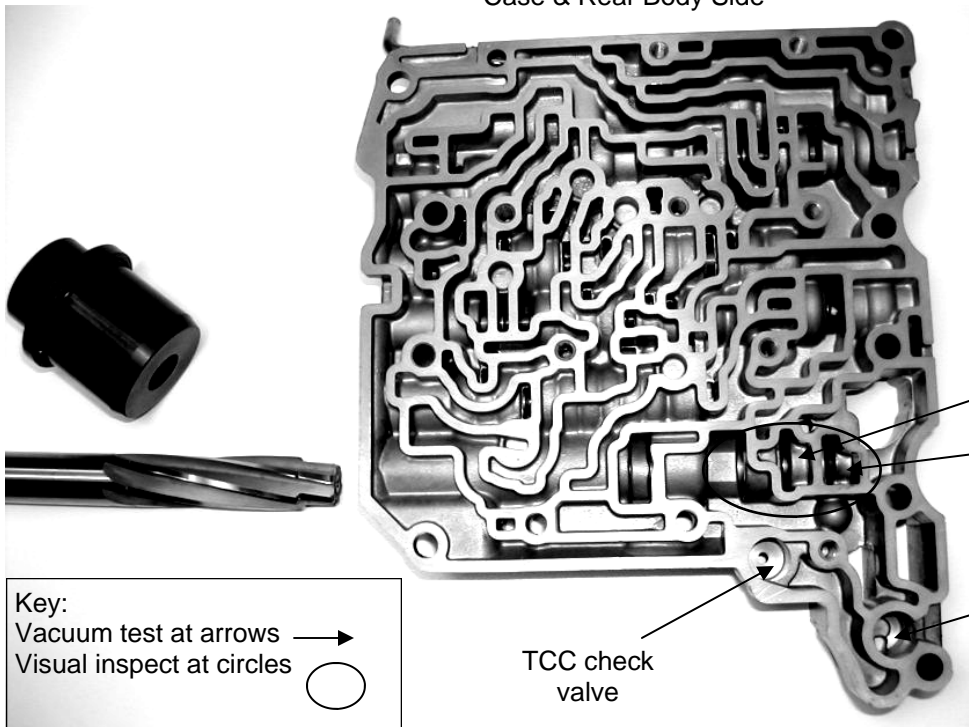

Vacuum test for
pressure
regulator valve
bore wear.

Cooler bypass.

TCC check
valve

Key:
Vacuum test at arrows →
Visual inspect at circles ○

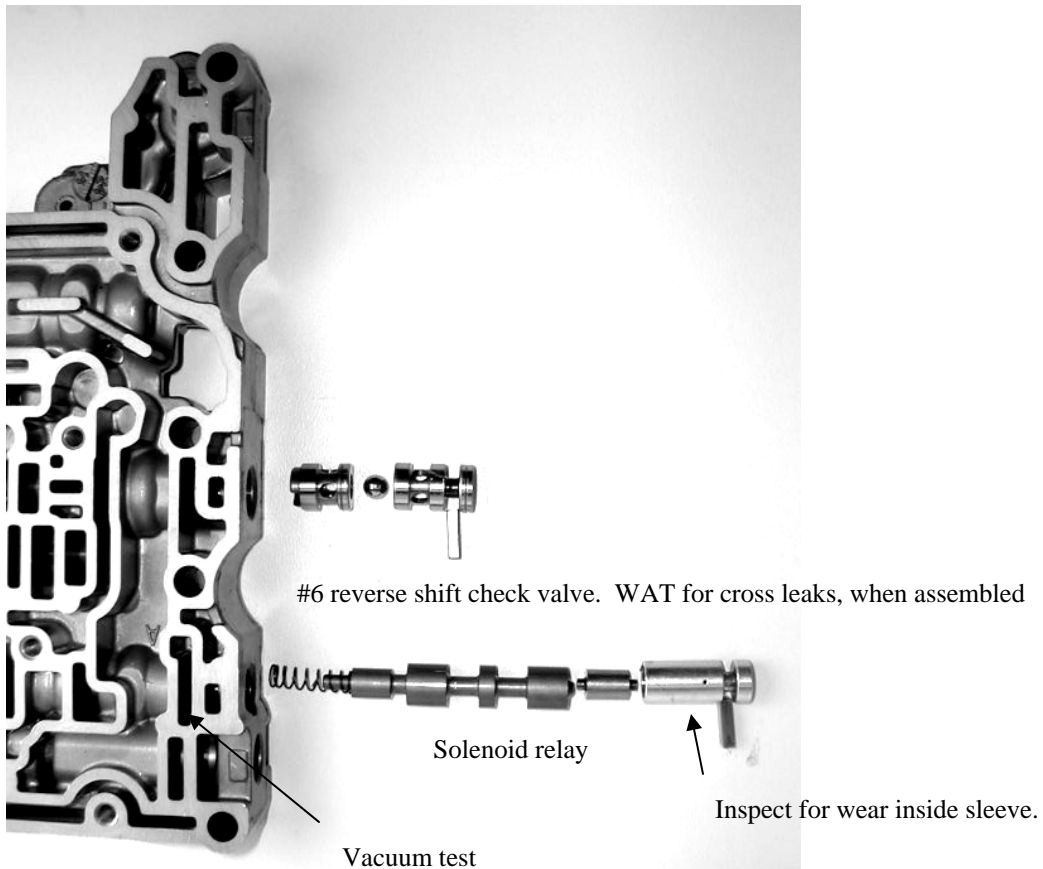
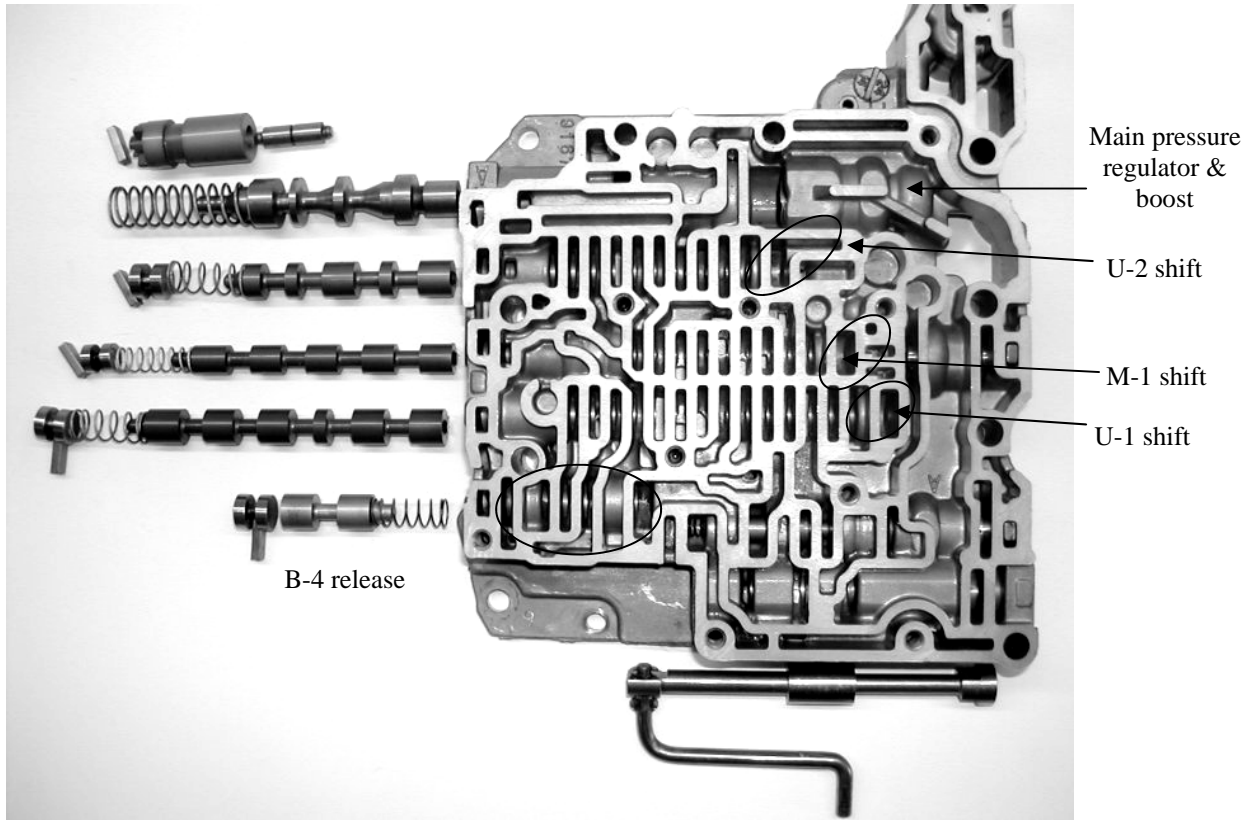

Rear Control Body

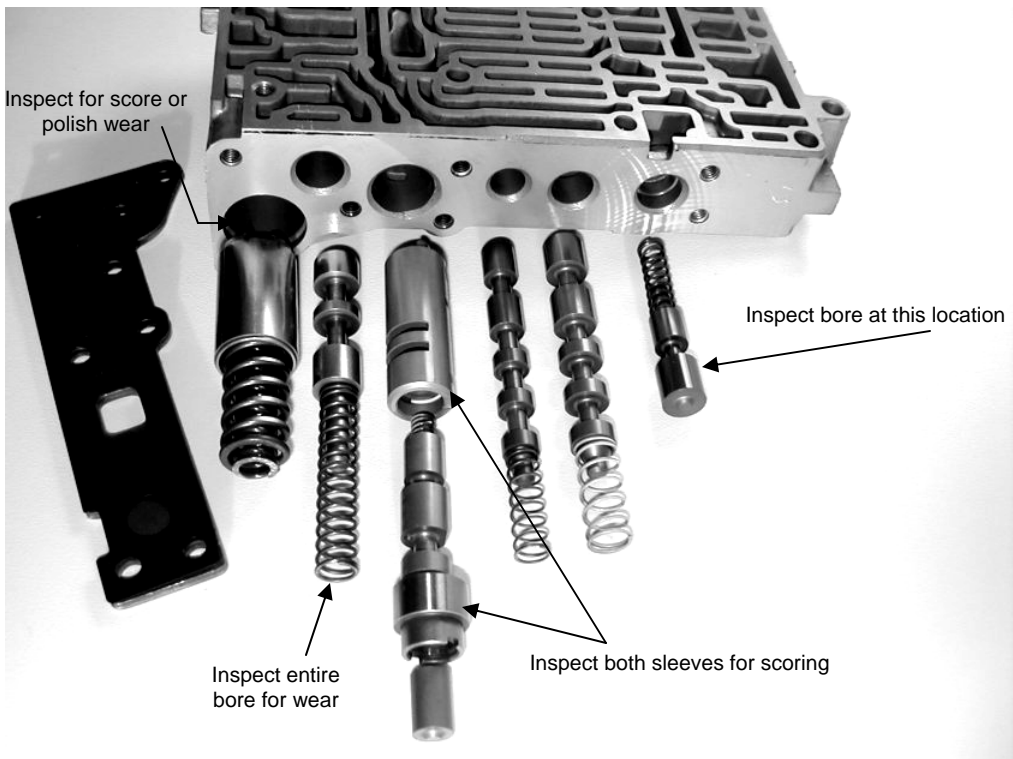
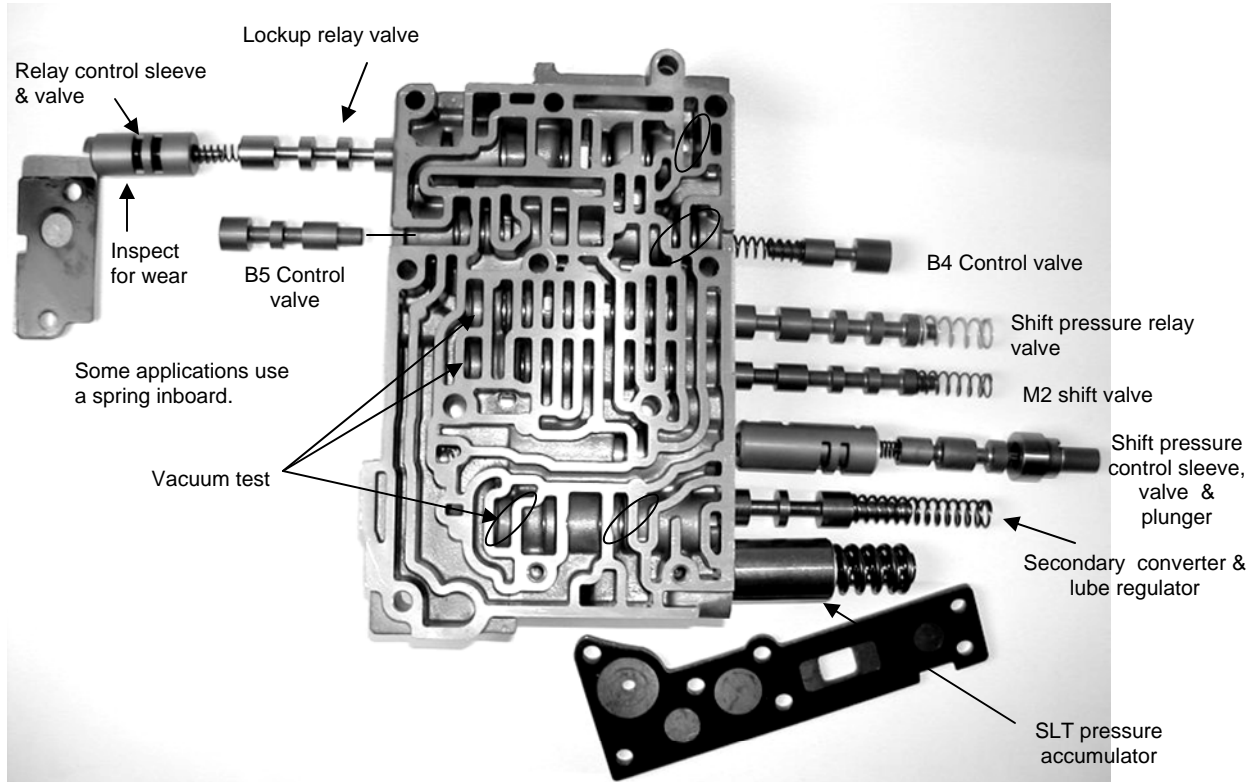

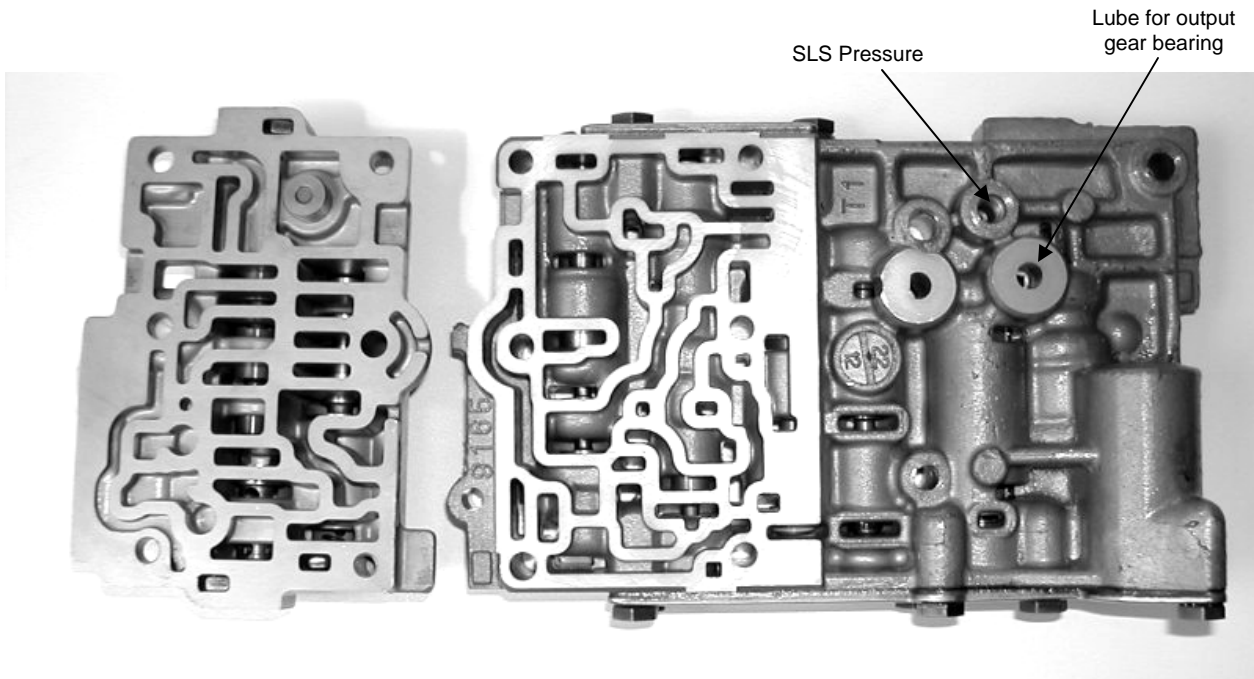

#2 Rear Control Valve Body

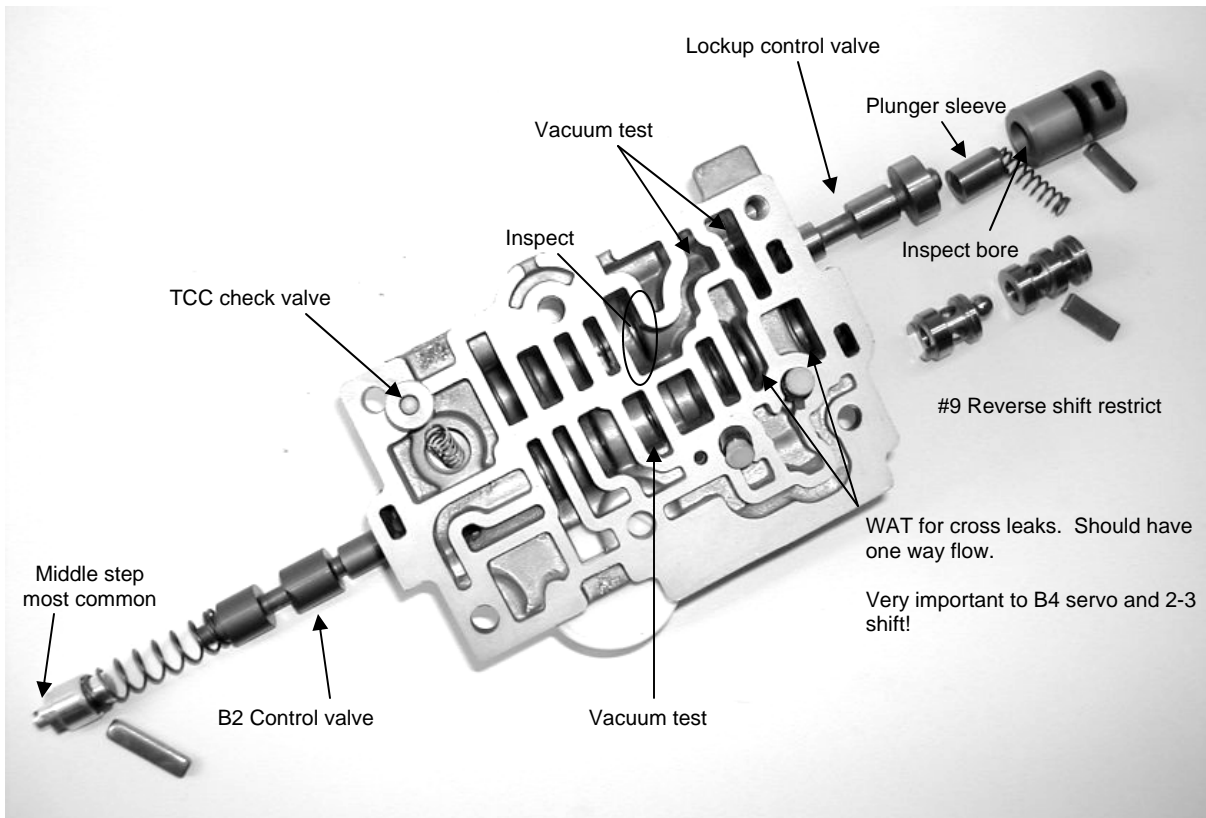

Separator Plates

Identification:

Plates must match the top & middle casting

A separator plate modification can be performed, if the secondary regulator bore has minimal wear. This modification will increase lube and converter feed oil flow. Enlarging the plate feed holes is not suggested if the valve body casting has excessive wear at the secondary regulator bore, in the area of the spring to spool surface.

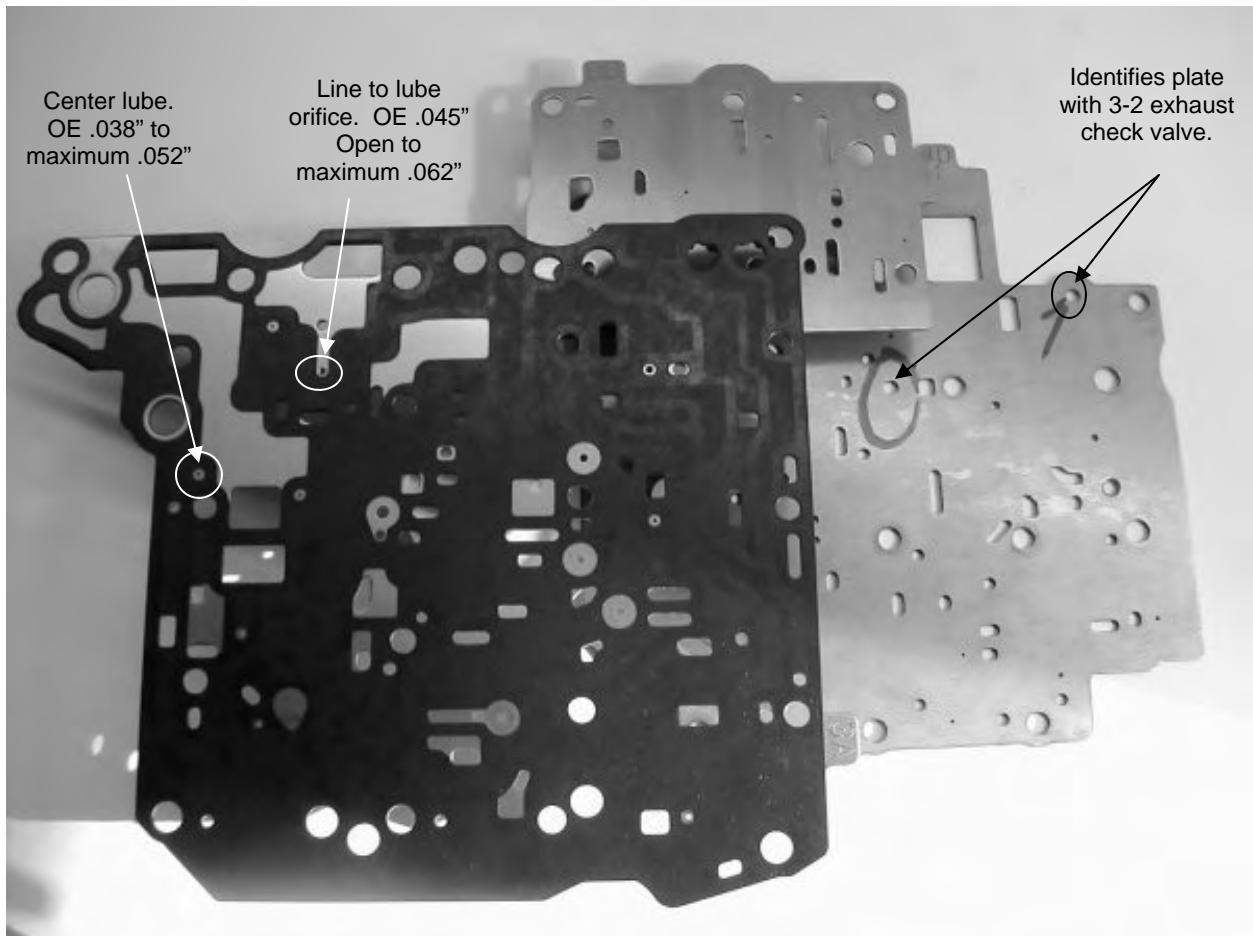

B4 servo apply/3rd gear band

- Passes through pump
- Into the B4 transfer tube w/o-ring
- On to B4 servo piston

Caution:

Anytime the valve body is lifted off the case the two seals tend to fall out of place. Use assembly gel to hold in place and double check prior to assembly.

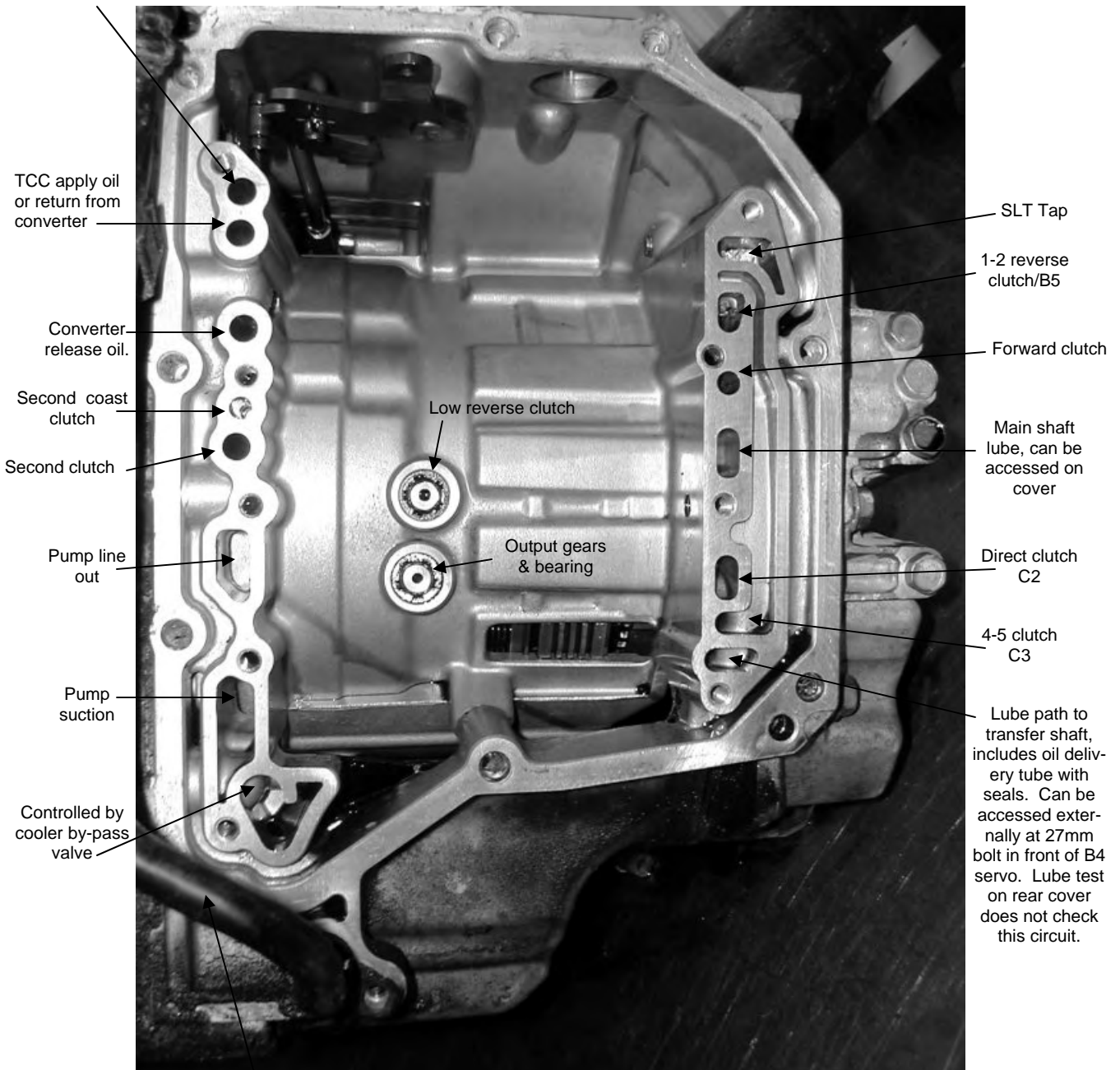

Volvo pictured
 Converter out line to cooler. Cooler returns into valve body cover.

AF 23/33
 Left side is converter out, right is return to sump.